



INSTALLATION INSTRUCTIONS



GENERAL INFORMATION:

The No. 1023-12 Alarm Processing Center is a local alarm panel with 3 memory zones plus a panic circuit. It has the following features:

Two Supervised Basic Protection Memory Zones for Normal and Fast Acting Perimeter and Interior Devices (two wire circuit with end-of-line resistor).

Automatic Zone Shunting with audible warning from optional sounder (permits closing even with one or both basic protection zones inoperative).

Entry/Exit Memory Zone with 45 (or 30) Second Entry and Exit Delay Times. Supervised. Entry delay may be eliminated via a remote switch.

24 Hour Emergency (Panic) Circuit.

LED Indication of AC Power, Zone Status and Alarm Memory by Zone (indicates alarm has taken place and bell has timed off).

Outputs for Bell(s) or high volume from Electronic Siren, Closure of Dry Contacts and (Optional) Early Warning Horn.

Automatic Alarm Cut-off after 12 (or 8, 16 or 24) minutes and Restore on All Intact Loops (will report a second alarm).

Bell and Battery Test Switch (AC power to battery charger disconnects during test).

Includes Low Voltage Plug-in Transformer and Built-in Rechargeable Power Supply (can supply 12V. continuous auxiliary load up to 300 ma).

System Turned ON and OFF from a Keyswitch (e.g.: No. 4235).

Remote Station(s) may be used instead, via an Adapter (e.g.: Nos. 244-12, 245-12, 216-12, or 5241-12).

Supervised Fire Circuit may be added by using a No. 245-12 Adapter or 263-12 Module.

INSTALLATION AND WIRING: See Figure 1.

Do not connect the battery or plug-in transformer until all other wiring has been completed.

Use of twisted wiring is recommended for all runs, for greater immunity to unwanted induced voltages.

Terminals

- 1,2 (Zone 1)
- 3,4 (Zone 2)

Basic Protection Zones 1 & 2: For each zone, run a pair of wires from that zone's terminals to all protection points in the zone and terminate with a 2000 ohm End-of-Line Resistor (supplied). Each loop has normal response to closed circuit devices (such as magnetic contacts, foil, etc.) connected in series. In Zone 1, for fast response to quick acting devices (such as vibration contacts and photoelectric units without built-in delays), cut the yellow jumper wire on the unit's chassis. (Zone 2: Cut the red wire for fast response.)

Note: If fast response is selected, the loop should not contain exposed metallic contacts (to lessen chance of false alarms).

An open or short in either loop will cause an immediate alarm when the system is ON.

Devices with open circuit contacts (such as mats) may be connected between the wires of either loop. (Do not use an Ademco No. 602 Mat Coupler.)

Maximum permissible resistance in each loop: 400 ohms (plus the 2000 ohm End-of-Line Resistor).

5,6

Entry/Exit Zone: Connect closed circuit contacts on the entry/exit door as well as interior contacts or sensors located in the path between the exit door and the control in a series wiring loop across these terminals. Maximum permissible loop resistance: 400 ohms.

This zone provides entry and exit times of 45 seconds each (30 seconds if the WHITE jumper is cut per Fig. 1).

For additional security (against shorts) a basic protection zone's loop may be routed along with the entry/exit loop as shown in Fig. 1. A short between these loops will result in an immediate alarm when the system is ON.

7,8

Emergency (Panic) Switches: Connect locking type open circuit emergency switches (such as Nos. 264, 266, 268 or 269) in parallel across these terminals.

Operation of an emergency switch at any time (system OFF or ON) will cause the alarm bell(s) to ring and the output contacts to close. Alarms activated from emergency switches do not cut off until the switches are reset.

9,14(+),16(-)

No. 706-12 Mini-Howler (Optional): Connect as shown in Fig. 1.

Will sound during entry delay.

Will also give steady warning during exit delay in case of accidental closing with entry/exit zone open or an intermittent tone if a basic protection zone is faulted and being automatically shunted.

10,11

Keyswitch: Connect a keyswitch, with key removable in "make" and "break" positions (such as No. 4235), across these terminals (OFF Position: Contacts CLOSED, ON Position: Contacts OPEN). A knockout is provided on the cover of the No. 1023-12 for panel mounting.

CAUTION: The switch may be located remotely provided the panel LED's can be seen when the system is turned ON or OFF. Otherwise, chances of unknowingly closing with protection not properly set are increased unless the optional No. 706-12 is installed.

Instead, remote station(s) showing system status may be used via an adapter (e.g.: Nos. 244-12, 245-12, 216-12, or 5241-12.

12,13

N.O. Dry Contacts: These contacts may be used to trip a digital communicator, telephone dialer or as desired. The contacts close on alarm (burglary or emergency) and open upon bell cut-off (burglary) or when emergency (panic) switches are manually reset. (The contacts do not close during bell test.) See CAUTION on Page 7.

ALL INTERCONNECTIONS MUST BE MADE USING UL LISTED LIMITED ENERGY CABLE.
 FOR COMPLETE INSTALLATION AND OPERATION INSTRUCTIONS, SEE
 TEXT AND OPERATORS' MANUAL P7972.

IF No. 245-12 REMOTE ADAPTER WITH FIRE LOOP IS USED, FOLLOW INSTALLATION REQUIREMENTS
 OF NFPA STANDARD No 74 (National Fire Protection Association, 470 Atlantic Avenue, Boston,
 MA 02210)

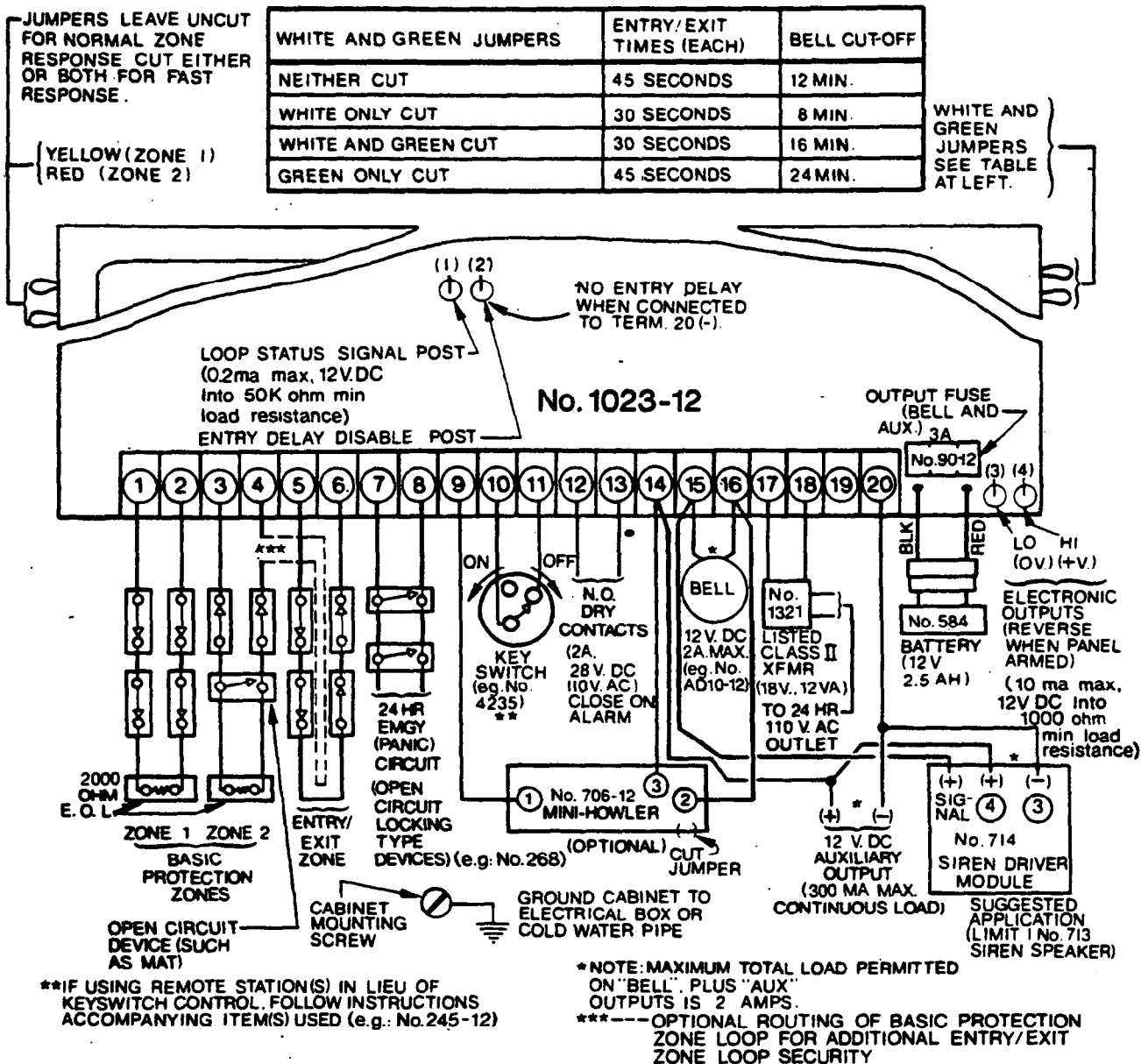

FIGURE 1: Field Connections, No. 1023-12

14,(+),20(-)

12V. DC for Auxiliary Equipment: Up to 300 ma continuous load can be connected to these terminals for powering units such as Nos. 1325-12, 1327-12 or 1356-12 Photoelectric Systems or Nos. 450-12 or 454-12 Ultrasonic Motion Detectors. During alarm, up to 2 amperes total combined load may be supplied by these and the alarm bell terminals 15 and 16.

15(+),16(-)

12V. DC Bells having a combined total rating of 2 amperes (less any auxiliary load connected to terminals 14 and 20) may be connected in parallel across these terminals.

Except during an emergency (panic) alarm, cut-off occurs after approximately 12 (or 8, 16 or 24) minutes (the Alarm Memory LED remains lit). After cut-off, the system will re-alarm if a disturbance subsequently occurs in any intact protection zone (including the originally disturbed zone if it has returned to normal).

17,18

Power Input, 18V. AC: Connect these terminals to the output terminals of the No. 1321 Transformer. Do not plug in the transformer yet.

Signal Posts

(1) Loop Status Signal Post: Used with remote (arming/disarming) station accessories. (Minimum recommended load resistance: 50K ohms.)

(2) Entry Delay Disable Post: When this post is connected to terminal 20 (through a switch, if desired) a disturbance in the "delay" zone will result in an immediate alarm while the system is armed (such as might be desired in a residence at night). Exit delay is not affected. Without this connection, normal entry and exit delay is present.

(3)LO (Zero V.)
 (4)HI (+ V.)
Electronic Output Signal Posts: These posts can be used to control accessories and/or provide opening and closing signals to a digital communicator. The levels indicated are present when the control is disarmed. The levels reverse when the control is armed. (Minimum load resistance: 1000 ohms.)

Ground Ground the cabinet to an electrical box or cold water pipe.

Black and Red Leads with Molex Connector Standby Battery: After all other wiring is completed, and with the keyswitch OFF, connect the battery to this plug when ready to proceed with TESTING AND CHECKOUT.

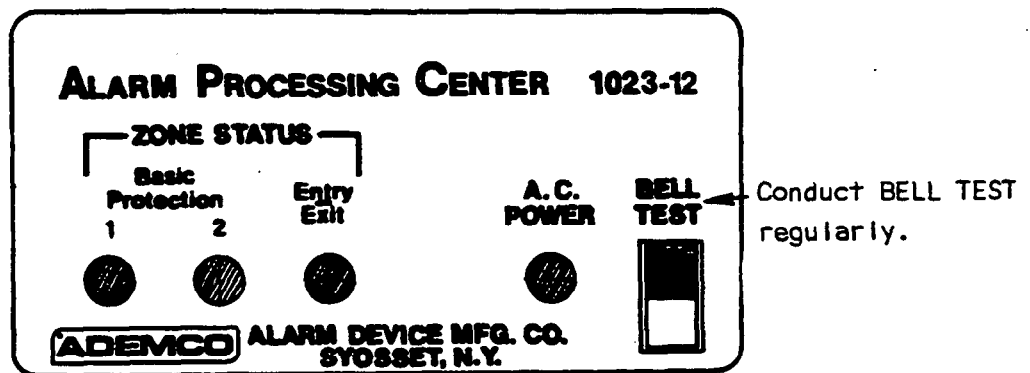

FIGURE 2: Indicators

TESTING AND CHECKOUT:

Perform these tests after the wiring and connections described in the previous section have been completed.

See Figure 2.

The keyswitch should be OFF. Turn it ON and OFF again.

1. Plug the transformer into a 110V. AC outlet that is ON 24 hours a day. The AC Power LED should light.
2. Observe the Zone Status LED's. None will be lit if the protective loops are properly wired and all contacts are properly set.
3. When all Zone Status LED's are out, do the following and observe the appropriate LED light in each case:
 - a. Open the zone 1 loop momentarily. The zone 1 LED should light while the loop is open. Repeat for zone 2 loop and LED.
 - b. Short the zone 1 loop momentarily. The zone 1 LED should light while the loop is shorted. Repeat for zone 2 loop and LED.
 - c. Open the entry/exit loop momentarily. The entry/exit zone LED should light while the loop is open.
4. Test the Bell(s) (and/or Electronic Siren) and Standby Battery by depressing the BELL TEST switch momentarily. The bell(s) should ring while the switch is depressed.

NOTE: The battery may not be fully charged. If this test is tried with a low battery there will not be enough power to ring the bell. Let the unit charge (transformer plugged in) for at least one-half hour if the battery is low. (If a siren is used and powered from terminals 14 and 20, depression of the BELL TEST switch sounds the siren, but tests the system with everything except the siren powered from the battery alone.)
5. Test the Emergency (Panic) Circuit by momentarily shorting terminals 7 and 8 or tripping an emergency switch: The bell(s) should ring only as long as the short remains.
6. Turn the system ON and simulate leaving the premises by following the procedure given in the OPERATION section.
7. Simulate entering the premises and turn the system OFF by following the procedure given in the OPERATION section.

OPERATION:

When Turning System ON:

1. AC Power LED should be lit at all times. If out, AC failure to unit is indicated.
2. Zone Status LED's should be off. If lit, protective loop is not set properly.

IMPORTANT: If either (or both) of the Basic Zone Status LED's is (are) lit, the control can be turned ON and the faulted zone(s) will automatically be shunted out and not cause an alarm although the No. 706-12 Mini-Howler (if installed) will give an intermittent tone during the exit delay time. If a faulted zone restores, however, a subsequent disturbance in its loop will cause an alarm. If the Entry/Exit Zone Status LED is lit, turning the control ON will cause an alarm, after 90 (60) seconds (exit plus entry delay time). In this case, the No. 706-12 Mini-Howler (if installed) will sound a steady warning immediately that an alarm can be avoided if the keyswitch is returned to OFF before 90 (60) seconds have expired.

3. Depress BELL TEST Switch to test bell and standby battery.

IMPORTANT: For continual assurance that bell and battery are in proper working order, regular performance of BELL TEST is advised. This is particularly important when remote arm/disarm keyswitches without LEDs are used.

4. Turn Keyswitch ON to arm system. Leave via entry/exit door within 45 (30) seconds. Note: The No. 706-12 Mini-Howler (if installed) will sound an intermittent tone while the door is open.

When Turning System OFF:

1. Enter only through entry/exit door. If a No. 706-12 Mini-Howler has been installed, it will sound during the entry delay period.
2. Turn Keyswitch OFF before end of entry delay period.

Note: The Zone Status LED's on the No. 1023-12 will go on and off as the protective loops open and close during normal operation of doors, windows, etc., while the system is OFF.

3. Note if an LED on panel is lit (it will be flashing if an alarm has taken place and the zone restored or on continuously if the zone is still open). To reset, turn the control ON and OFF again.

ACCESSORIES:

Instead of using a keyswitch to control the panel, up to 4 remote stations (e.g.: Nos. 214, 231, 246, 246R, 5231 or 5246) may be used via one of the following adapters (each remote station shows system status via a single LED):

- No. 244-12 Two Wire Remote Adapter
- No. 245-12 Two Wire Remote Adapter Module with Supervised Fire Loop

Alternatively, the following are available for coded pushbutton control of the panel:

No. 215-12 Two Wire Digital Remote Station with Panic Circuitry (up to 4 can be used, via a No. 216-12 Adapter)

or

No. 5241-12 Self-contained Digital Remote Station (only one can be used...no adapter needed)

Complete information is contained in the individual installation instructions for the above.

Other accessories may be used if they do not draw more than 300 ma continuous current (at 12V. DC) from terminals 14 (+) and 20 (-). Total current on alarm (including alarm sounding device plus unregulated output) should not exceed 2 amperes.

SPECIFICATIONS:

Physical: Width: 8" (20.3 cm) Height: 15" (38.1 cm) Depth: 3" (7.6 cm)

Electrical: Voltage: 18V. AC (from No. 1321 Plug-in Transformer)

 Current (per Loop): 4 ma

 Maximum Resistance (per Loop): 400 ohms₄₉₆

Auxiliary plus Unregulated plus
 Bell Circuit Outputs: 2 A maximum
 Fuse, 12V. DC (Auxiliary
 plus Bell) Outputs: 3 A (No. 90-12)
 Output Relay Contacts: SPST, Rating: 2A at 28V. DC/110V. AC

Standby: 6 cell Sealed Lead Acid Rechargeable Battery (Ademco No. 584). Up to 60 hours standby with no accessories. Standby with accessories depends upon continuous load supplied.

MAXIMUM STANDBY TIMES WITH VARIOUS AUXILIARY CIRCUIT CONTINUOUS LOADS*							
ma:	0	50	100	150	200	250	300
Hrs:	60	30	18.5	13	10	8	6.5

*Loads in addition to control panel and loop currents

CAUTION

Digital Communicators (or Dialers) shall not be set or programmed to place a call to a police station number which has not been specifically assigned by that police station for such service.

TO THE INSTALLER

Regular maintenance by the installer and frequent testing by the user is vital to continuous satisfactory operation of any alarm system.

The installer should assume the responsibility of developing and offering a regular maintenance program to the user as well as acquainting the user with the proper operation and limitations of the alarm system and its component parts. Recommendations must be included for a specific program of frequent testing to insure the system's proper operation at all times.

SUPPLEMENTARY INSTRUCTIONS: No. 1023 ALARM PROCESSING CENTER

RE: USE OF 12V. DC BELL OR SELF-CONTAINED ELECTRONIC SIREN

If desired (on non-U.L. installations) a 12V. DC BELL (such as the No. 1011-12 Bell in Box) or a SELF-CONTAINED ELECTRONIC SIREN (such as the No. 702) may be operated from the No. 1023's 12V. DC Unregulated Power Output Terminals 19(+) and 20(-).

Connect one side of the BELL [or negative (-) lead of the SIREN] to terminal 20(-). Connect the other side of the BELL [or positive (+) lead of the SIREN ("Warble" or "Steady" on the No. 702)] via Dry Contact Terminals 12 and 13 to terminal 19(+).

- NOTES:
1. Bell Test should be conducted regularly by operating a panic circuit device connected across terminals 7 and 8. The panel's internal dry contacts across terminals 12 and 13 close only on alarm. The dry contacts DO NOT close when the BELL TEST switch is depressed.
 2. The No. 702 Electronic Siren, if used, will emit a slightly rougher tone from the panel's unregulated output than it would from regulated DC.
 3. During alarm, the total combined load on terminals 19 and 20 plus 14 and 20 plus 15 and 16 must not exceed 2 amps.
 4. If AC input to the panel is not present, the 12V. output drops to 6V.

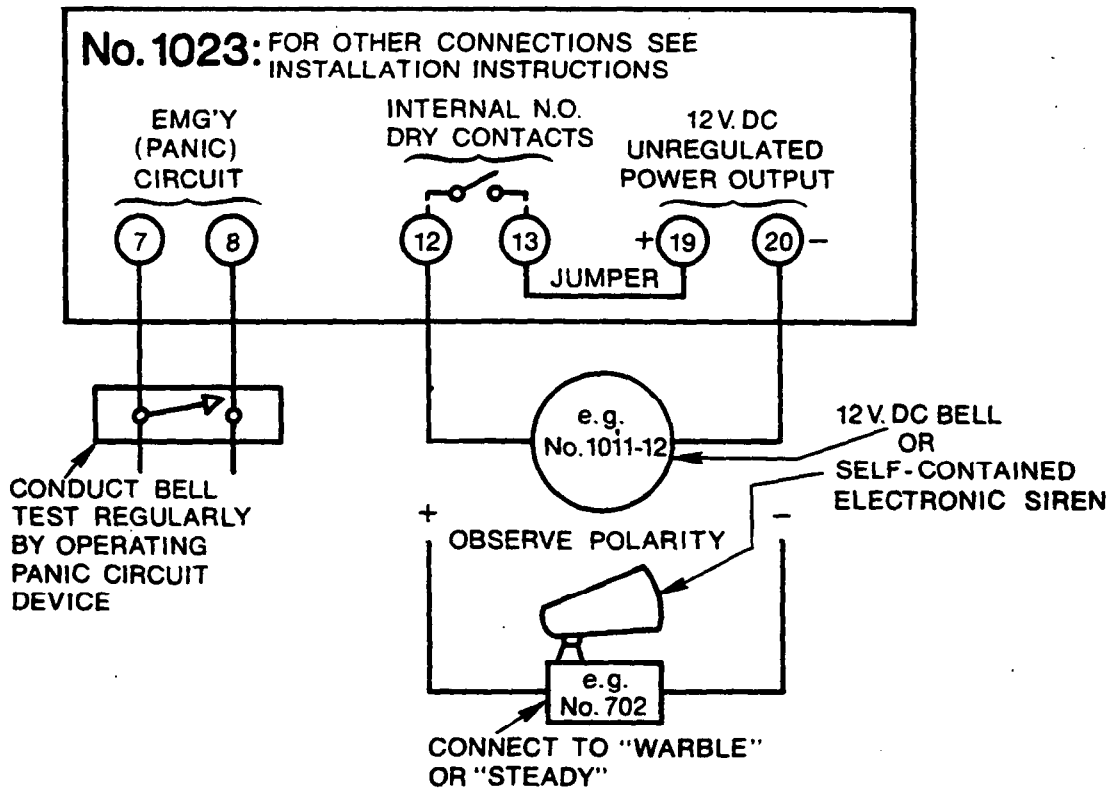

ALARM DEVICE MANUFACTURING CO.

498 A DIVISION OF PITNEY CORPORATION

165 Eileen Way, Syosset, New York 11791

P4882 11/79

ADDENDUM TO: **INSTALLATION INSTRUCTIONS**
for
NO. 1023 ALARM PROCESSING CENTER

RE: **INCREASED AUXILIARY OUTPUT CAPACITY**

The available continuous auxiliary output of this alarm processing center has been increased to 600mA at 6V.DC (formerly 350mA).

Accordingly, any mention of the former value in the accompanying copy of the installation instructions should be changed to the new one.

In the SPECIFICATIONS section, the "MAXIMUM STANDBY TIMES..." table should have the following substituted for it:

MAXIMUM STANDBY TIMES* WITH VARIOUS AUXILIARY CIRCUIT CONTINUOUS LOADS**													
ma:	0	50	100	150	200	250	300	350	400	450	500	550	600
Hrs:	50	24	15	10.5	8	6.5	5.5	5	4	3.6	3.3	3	2.7

*Assuming an "auxiliary" plus "alarm sounder" current drain, on alarm, of 2 amps and an alarm sounding time of at least 15 minutes (standby times will be longer if alarm current is less and/or sounder cutoff occurs sooner).

**Loads in addition to control panel and loop currents.

ADEMCO

P4576V1XX 4/83

ALARM DEVICE MANUFACTURING CO.

A DIVISION OF PITTMAY CORPORATION

165 Eileen Way, Syosset, New York 11791

Copyright © 1983 PITTMAY CORPORATION