



INSTRUCTIONS FOR INSTALLATION AND USE

MN-240 SERIES DC-POWERED SMOKE DETECTORS

READ THIS INSTRUCTION SHEET THOROUGHLY BEFORE
INSTALLING AND USING YOUR MERIDIAN SMOKE DETECTOR

Features

- **Advanced 90° photoelectric detection pattern and specially designed smoke chamber*** for superior detection and dust resistance
- **Unique high signal-to-noise ratio and superior RFI immunity to prevent false alarms**
- **Excellent smoke access provides reliable detection for all smoke flow directions and velocities**
- **Optional Loud 85dB piezoelectric alarm horn**
- **Solid-state LED red Indicator Light**
- **Form A (normally opened, alarm closed) alarm relay (standard); optional Form C (normally opened/normally closed) auxiliary relay**
- **57°C (135°F) fixed temperature heat sensor option**
- **Magnet-activated Sensitivity Test Switch**
- **The unit will automatically perform a self-test once every 40 seconds and provide an audible trouble indication (in sounder-equipped units) if the unit has insufficient smoke sensitivity**
- **Attractive styling for any decor**
- **ULC listed S529**

* Protected under Canadian Patent No. 1452296. Other patents pending.

Models

MN240	Form "A" Alarm Relay
MN240T	Form "A" Alarm Relay and Fixed Temp (57°C) Sensor
MN240R	Form "A" Alarm Relay and Auxiliary Form "C" Relay
MN240RT	Form "A" Alarm Relay and Auxiliary Form "C" Relay and Fixed Temp (57°C) Sensor
MN240S	Form "A" Alarm Relay and Sounder
MN240ST	Form "A" Alarm Relay and Sounder and Fixed Temp (57°C) Sensor
MN240SR	Form "A" Alarm Relay and Sounder and Auxiliary Form "C" Relay
MN240SRT	Form "A" Alarm Relay and Sounder and Auxiliary Form "C" Relay and Fixed Temp (57°C) Sensor

Introduction

The DSC Meridian MN 240 Series Smoke Detectors are four-wire smoke detectors intended for open area protection. They are suited for commercial, institutional and residential fire alarm systems.

The DSC Meridian Photoelectric Smoke Detector incorporates many advanced design features to provide years of reliable operation. It is important to follow the Installation and Operation instructions on this sheet to ensure that the unit will function properly — even the best designed smoke detector will be rendered useless if it is not connected or located properly.

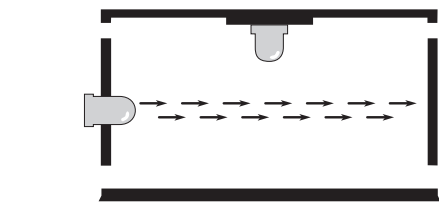

Normally, light pulses in the Smoke Chamber do not reach the light sensor

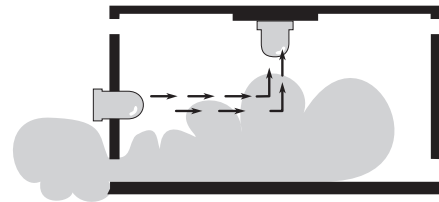

Smoke in the Smoke Chamber deflects light into the light sensor, triggering an alarm.

It is very important that you understand how to test and maintain your system. Refer to the Instruction or User Manual for your alarm system, and familiarise yourself with how the Fire Alarm functions of your system operate. Be sure to test your system regularly following the test procedures described in your manual. If you should ever have problems operating or testing your system, and especially if there are problems with the Fire Alarm functions, contact your Smoke Detector Installer or Dealer immediately for service.

While smoke detectors and alarm systems are designed to warn you of potentially dangerous situations, no system can prevent emergencies. An alarm system is not a substitute for life and property insurance; you should always maintain appropriate insurance coverage.

How the Smoke Detector Works

As shown in the illustration, a light source is directed across the smoke chamber and is not normally reflected into the sensing element. When smoke enters the chamber, the light beam is scattered by the smoke and is reflected into the sensor. When enough light is detected by the sensor, an alarm is activated. On alarm, the Alarm Indicator Light will come ON and the Alarm Relay is activated to send an alarm signal to the control panel. The Sounder and the Auxiliary Relay, if equipped, are also activated on alarm.

When the smoke clears from the smoke chamber, the unit will only reset the Sounder. The Relay(s) and Indicator Light will remain in the alarm state until reset by turning off the power supply from the control panel.

Alarm Indications

Condition	Alarm LED	Relay(s)	Sounder (if equipped)
No Smoke or Heat	Pulse every 40 s	Deactivated	Silent
Smoke or Heat	ON steady	Activated	Alarm
Automatic Self Test Functioning Normally	Pulse every 40 s	Deactivated	Silent
Automatic Self Test Insufficient Sensitivity	Pulse every 40 s	Deactivated	Chirp every 40 s
Sensitivity Test Functioning Normally	ON Steady	Activated	Alarm
Sensitivity Test Insufficient Sensitivity	Pulse every 40 s	Deactivated	Silent
No Smoke or Heat but Latched in Alarm	ON steady	Activated	Silent

Limitations of Smoke Detectors

While the Meridian Smoke Detector has been designed for reliability, it is important to know that all smoke detectors have limitations.

- Smoke detectors will not work without power. Devices powered from a control panel will not function if the control panel's AC and battery backup power supplies both fail.
- Smoke detectors can only generate an alarm when smoke gets inside the Smoke Chamber; anything that prevents smoke from entering the Smoke Chamber may prevent or delay an alarm. Refer to the Guidelines for Locating Smoke Detectors on this Instruction Sheet; it is important that smoke detectors be located on at least every floor of the premises, preferably in every room. It is also important to avoid obstructions, such as closed doors, that may prevent smoke from reaching the unit. A smoke detector will not detect a fire in the walls, in the chimney or on the roof of a building until smoke enters the Smoke Chamber.
- Smoke detectors have certain obvious limitations: they may not provide protection for someone smoking in bed, for children playing with matches, or for sudden and violent explosions. A smoke detector is a single part of overall fire safety precautions; the smoke detector should never be seen as a substitute for a complete fire safety program.

Guidelines for Locating Smoke Detectors

On smooth ceilings, detectors may be spaced 9.1m (30 feet) apart as a guide. Other spacings may be required depending on ceiling height, air movement, the presence of joists, uninsulated ceilings, etc. Consult NFPA 72 (1993), CAN/ULC-S553-M86 or other appropriate national standards for installation recommendations.

Do not locate smoke detectors at the top of peaked or gabled ceilings; the dead air space in these locations may prevent the unit from detecting smoke.

Avoid areas with turbulent air flow, such as near doors, fans or windows. Rapid air movement around the detector may prevent smoke from entering the unit.

Do not locate detectors in areas of high humidity.

Do not locate detectors in areas where the temperature rises above 38°C (100°F) or falls below 5°C (41°F).

● Smoke detectors for minimum protection
Figure 1

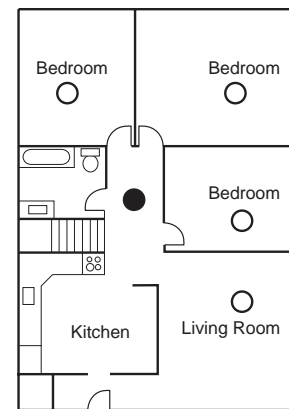

○ Smoke detectors for better protection
Figure 2

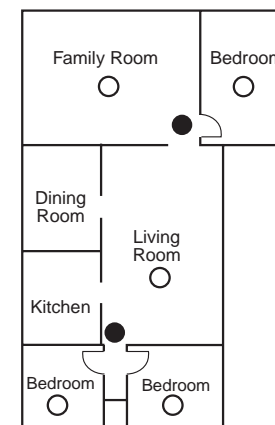

Smoke detectors should always be installed in accordance with NFPA 72, the National Fire Alarm Code. Smoke detectors should always be located in accordance with Paragraph 2.1.1.1 of NFPA 72, Chapter 2.:

"2-2.1.1.1 Smoke detectors shall be installed outside of each separate sleeping area in the immediate vicinity of the bedrooms and on each additional story of the family living unit, including basements and excluding crawl spaces and unfinished attics. In new construction, a smoke detector also shall be installed in each sleeping room."

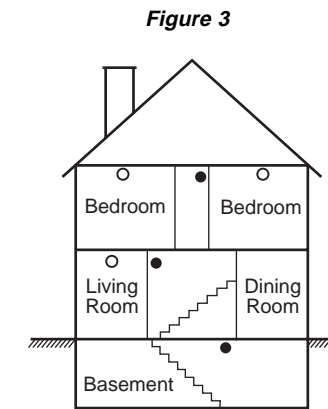

Figure 3

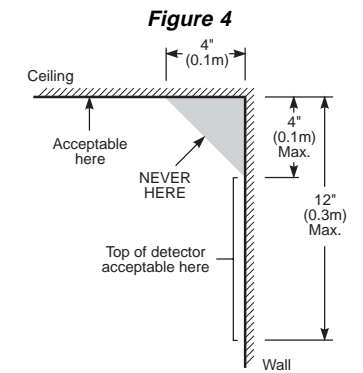
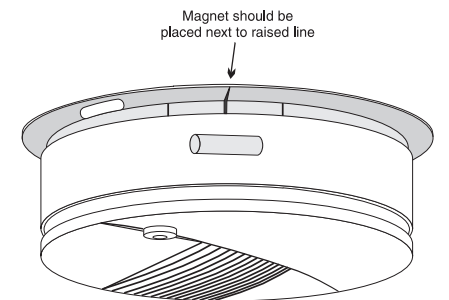

Figure 4

NOTE: Measurements shown are to the closest edge of the detector.

Testing Your Smoke Detector

Never use burning or smouldering materials to test a smoke detector. Also, do not use high pressure aerosols to test smoke detectors. The use of burning materials or high pressure aerosols can give misleading and meaningless results.



Test the detector for minimum sensitivity by activating the test feature. To test the unit, hold the test magnet against the case as shown below. The Alarm Indicator Light will come ON, the Alarm Relay will be activated, the Sounder (if equipped) will sound, and the alarm control panel should indicate a fire alarm. When the magnet is removed, the Sounder will be silenced, but the Alarm Light and Relay will remain ON. Turn off the voltage supply to the detector for two seconds to reset the detector to normal.

If the smoke detector does not function properly, call your Smoke Detector Installer or Dealer for service.

Smoke Sensitivity may be measured in a correlated UL217 or CAN/ULC S529-M87 smoke box. DSC will conduct this test for a nominal charge. If a returned unit is found outside of its marked sensitivity range, DSC will clean and restore the unit's sensitivity to its marked range.

Smoke sensitivity of installed detectors can be measured without removal with the Gemini Model 501 Aerosol Smoke Detector Analyzer. Follow the instructions supplied with the instrument. Start with the sensitivity corresponding to the lowest marked detector sensitivity; no alarm should be indicated. Reset with the highest sensitivity setting; an alarm should then be indicated. These results indicate that the unit is within its marked sensitivity range. Other settings can be tried to bracket the detector's sensitivity to a narrower sensitivity range, such as may be important during annual tests to quantify any change over time.

Owner's Maintenance Instructions

The Meridian Smoke Detector is designed to require a minimum of maintenance. If the case becomes dusty, wipe the case gently with a soft dry cloth. If the case is greasy, wipe the case gently with a soft cloth slightly dampened with soapy water.

Never disassemble the smoke detector; there are no user serviceable parts inside the unit. Never paint the unit, as paint may prevent smoke from entering the unit. If you are planning renovations or repainting, contact your Installer and ask that the unit be temporarily removed until work is complete.

If the unit is located in an area where it is exposed to high levels of dust or insects and is found to cause false alarms, it may require service; contact your Smoke Detector Installer or Dealer.

Fire Safety In The Home

Most fires occur in the home, and to minimize this danger, it is recommended that a household fire safety audit be conducted and a family escape plan be developed.

Household Fire Safety Audit

- 1 Are all electrical appliances and outlets in a safe condition? Check for frayed cords, overloaded lighting circuits, etc. If you are uncertain about the condition of your electrical appliances or household service, have a professional evaluation.
- 2 Are all flammable liquids stored safely in closed containers in a cool, well ventilated area? Cleaning with flammable liquids should be avoided.
- 3 Are hazardous materials such as matches out of the reach of children?
- 4 Are furnaces and wood burning appliances properly installed, clean and in good working order? If in doubt, have a professional evaluation.

Family Escape Planning

There is often very little time between the detection of a fire and the time it becomes deadly. Because of this, it is very important that a family escape plan be developed and rehearsed.

- 1 Every family member should participate in developing the escape plan.
- 2 Study the possible escape routes from each location within the house. Since many fires occur at night, special attention should be given to the escape routes from sleeping quarters.
- 3 It is essential that escape from a bedroom be possible without opening the interior door. Consider the following when making your escape plans:
 - Make sure that doors and windows that open to the outside are easily opened. Ensure that they are not painted shut, and that their locking mechanisms operate smoothly.
 - If opening the exit or using the exit is too difficult for children, the elderly or handicapped, plans for rescue should be developed. This includes making sure that those who are to perform the rescue can promptly hear the fire warning signal.
 - If the exit is above the ground level, an approved fire ladder or rope should be provided, as well as training in its use.
 - Exits on the ground level should be kept clear. Be sure to remove snow from exterior patio doors in winter; outdoor furniture or equipment should not block exits.
 - The family should have a predetermined assembly point where everyone can be accounted for; for example, across the street or at a neighbour's house.
 - Once everyone is out of the house, call the Fire Department.
 - A good plan emphasizes quick escape. Do not investigate first or attempt to fight the fire, and do not attempt to rescue belongings or valuables as this takes up time. Once outside, do not re-enter the house; wait for the Fire Department.
- 4 Write the plan down and rehearse frequently so that should an emergency arise, everyone will know what to do. Revise the plan as conditions change; for example, when there are more or fewer family members in the home, or if there are changes to the house.
- 5 Make sure your fire warning system is operational by conducting weekly tests. If you are unsure about system operation, contact your Smoke Detector Installer or Dealer.
- 6 It is recommended that you contact your local fire department and request further information on home fire safety and escape planning. If available, have your local fire prevention officer conduct an in-house fire safety inspection.

Installation Instructions

Specifications

Nominal Operating Voltage 12 - 24VDC or VFWR
Maximum Operating Voltage Range 10 - 30VDC, or
 10 - 26.4VFWR

	Standby Current		Alarm Current @ 12 & 24V
	@ 12V	@ 24V	
MN240	15µA	45µA	35mA
MN240T	25µA	60µA	35mA
MN240R	15µA	45µA	60mA
MN240RT	25µA	60µA	60mA
MN240S	15µA	45µA	45mA
MN240ST	25µA	60µA	45mA
MN240SR	15µA	45µA	70mA
MN240SRT	25µA	60µA	70mA

Relay Rating (Resistive)

Form A Relay 1A at 30VDC / 24VAC
 Form C Relay 2A at 30VDC / 24VAC

Smoke Sensitivity 2.5%/ft obscuration ±0.5%/ft

Operating Environment 0°C - 50°C (32°F - 122°F)
 5% - 95% RH, non-condensing

Field Test Magnet-activated switch and/or
 Gemini 501 Smoke Alarm Analyser**

** Gemini Scientific, 1122B Aster Ave., Sunnyvale, CA 94086
 Tel: 408-554-0310

Dimensions

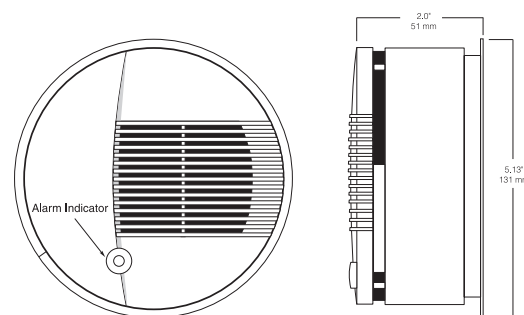

Mounting the Unit

The Meridian Smoke Detector mounts to a standard 4" octagonal electrical box. **12 to 24Vdc or Full Wave Rectified power must be supplied from a ULC-listed power supply or the auxiliary power terminals of a ULC-listed alarm control unit. Wiring should be in accordance with the Canadian Electrical Code, Part I, and applicable local codes.**

Remove the mounting plate from the case by pushing the locking tab and turning the mounting plate counter-clockwise. Attach the mounting plate to the electrical box (see diagram below for orientation).

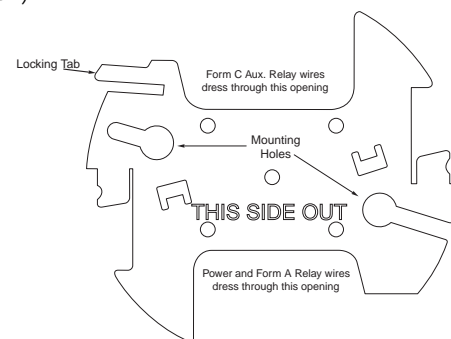

Smoke Detector Mounting Plate

Wiring

Refer to the wiring diagrams on this installation sheet and those provided in the Installation Manual of the alarm control panel being used with the unit.

Before connecting the unit, prepare the wires from the electrical box for connection; the wires should not be frayed or bent.

CAUTION: If the power connections are reversed, the unit will not operate. The unit is protected against damage from incorrect wiring.

When wiring is completed, inspect the wiring and correct any errors before applying power to the unit. When the wiring has been thoroughly reviewed, neatly insert the wires into the electrical box and secure the unit to the mounting plate.

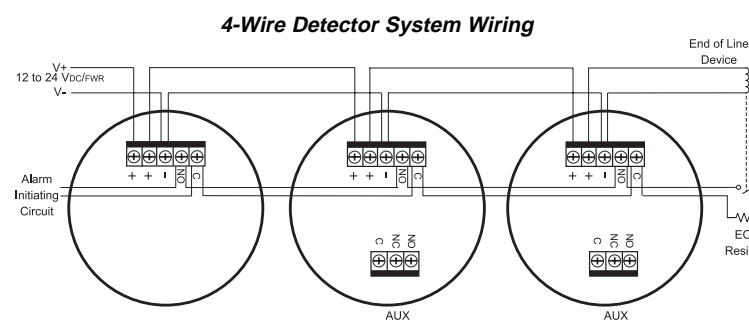
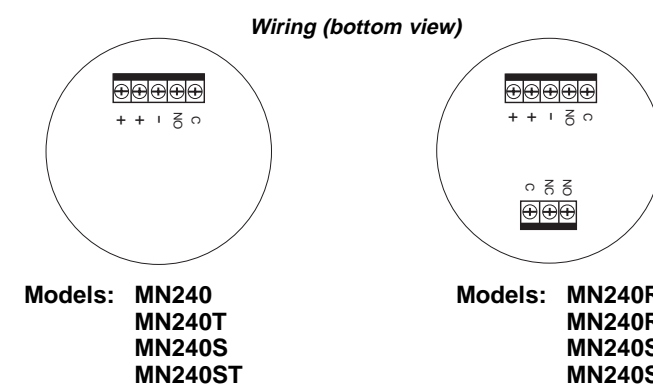

Installation Testing

When all connections are completed, apply power to the system as described in the control panel's Installation Manual. If all connections are correct, there should be no alarm from any of the smoke detectors. If an alarm occurs, ensure that there is not an actual alarm condition. If there is no actual alarm, remove power from the system and check all smoke detectors for correct wiring.

If no alarm occurs, test each smoke detector by holding the test magnet against the case near the Alarm Indicator. Refer to the illustration in the "Testing Your Smoke Detector" section of these instructions. When the magnet is in place, an alarm will be activated: the Alarm Indicator Light will come ON, the Alarm Relay will be activated, the Sounder (if equipped) will sound, and the alarm control panel will indicate a fire alarm. When the magnet is removed, the Sounder will be silenced and the detector will remain latched in the alarm condition. To reset the detector, remove the power supplied by the alarm control panel.

Installer's Maintenance Instructions

Normally, the Meridian Smoke Detector will not require maintenance. If the unit is mounted in a high dust environment, the inlet areas of the case may be vacuumed with a soft brush attachment.

Be sure to inform the user and their monitoring station when maintenance of any sort is performed on the smoke detector or any part of the alarm control system. Always test smoke detectors after maintenance. If a smoke detector continues to generate nuisance alarms even after vacuuming, return the unit to DSC for service. Contact DSC at the address and number below to obtain a return authorisation number before returning the unit.

Installer's Responsibility to the User

It is the Installer's responsibility to thoroughly instruct the end user of the system on the operation, testing and maintenance of their system. The Installer should fully explain and demonstrate all functions of the alarm control system and any equipment, such as smoke detectors, connected to it. The user should be provided with all Instruction Sheets and Manuals for their system and any components connected to it. Complete and thorough instruction for the user is essential to ensure they will obtain the greatest benefit from their system. Providing the user with complete operational information will also benefit the Installer through a reduction in service calls for nuisance alarms.

Limited Warranty

Digital Security Controls Ltd. warrants that for a period of twelve months from the date of purchase, the product shall be free of defects in materials and workmanship under normal use and that in fulfillment of any breach of such warranty, Digital Security Controls Ltd. shall, at its option, repair or replace the defective equipment upon return of the equipment to its repair depot. This warranty applies only to defects in parts and workmanship and not to damage incurred in shipping or handling, or damage due to causes beyond the control of Digital Security Controls Ltd. such as lightning, excessive voltage, mechanical shock, water damage, or damage arising out of abuse, alteration or improper application of the equipment.

The foregoing warranty shall apply only to the original buyer, and is and shall be in lieu of any and all other warranties, whether expressed or implied and of all other obligations or liabilities on the part of Digital Security Controls Ltd. Digital Security Controls Ltd. neither assumes, nor authorizes any other person purporting to act on its behalf to modify or to change this warranty, nor to assume for it any other warranty or liability concerning this product.

In no event shall Digital Security Controls Ltd. be liable for any direct, indirect or consequential damages, loss of anticipated profits, loss of time or any other losses incurred by the buyer in connection with the purchase, installation or operation or failure of this product.

Smoke detectors that are a part of this system may not properly alert occupants of a fire for a number of reasons, some of which follow. The smoke detectors may have been improperly installed or positioned. Smoke may not be able to reach the smoke detectors, such as when the fire is in a chimney, walls or roofs, or on the other side of closed doors. Smoke detectors may not detect smoke from fires on another level of the residence or building.

Every fire is different in the amount of smoke produced and the rate of burning. Smoke detectors cannot sense all types of fires equally well. Smoke detectors may not provide timely warning of fires caused by carelessness or safety hazards such as smoking in bed, violent explosions, escaping gas, improper storage of flammable materials, overloaded electrical circuits, children playing with matches or arson.

Even if the smoke detector operates as intended, there may be circumstances when there is insufficient warning to allow all occupants to escape in time to avoid injury or death.

Warning: Digital Security Controls Ltd. recommends that the entire system be completely tested on a regular basis. However, despite frequent testing, and due to, but not limited to, criminal tampering or electrical disruption, it is possible for this product to fail to perform as expected.

Important Information: Changes or modifications not expressly approved by Digital Security Controls Ltd. could void the user's authority to operate this equipment.

For Information and Technical Assistance:

DSC™ © 1997 Digital Security Controls Ltd.
 1645 Flint Road, Downsview, Ontario, Canada M3J 2J6
 Security Products Phone: (416) 665-8460 • Fax: (416) 665-7498