

E-FSC conventional small building fire alarm solutions

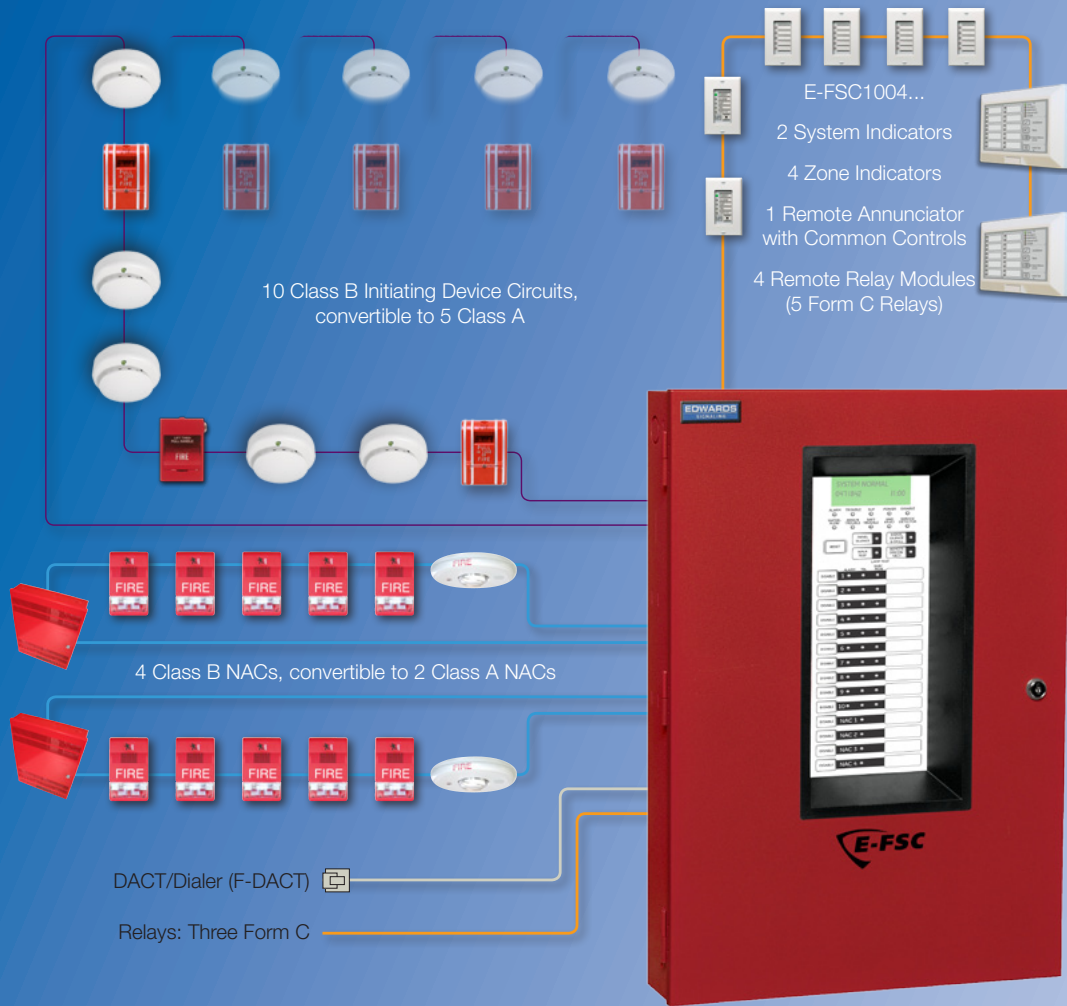

The simplicity of conventional wiring with valuable features found only among high-end systems.

- CleanMe® feature provides remote annunciation if compatible detector drifts out of UL limits
- Automatic drift compensation extends detector life
- Precision UL 1971 signal synchronization and optional audible silence over just two wires
- Up to 7 amps available NAC power cuts equipment costs
- Fully integrated upload/download communications enables PC programming and off-premise monitoring
- Zone or NAC pairs convertible to single Class A circuits
- Combination Waterflow and Supervisory zones
- NACs programmable by zone and individually selectable for continuous, temporal or coded outputs, or Genesis protocol

10-zone model illustrated. 5-zone and 3-zone models also available. See table for specifications.

Specifications		E-FSC1004					E-FSC502			E-FSC302	
Initiating Device Circuits – IDCs (Available combinations shown at right)	Class B	10	8	6	4	2	0	5	3	0	Three Class B IDCs
	Class A	0	1	2	3	4	5	0	1	2	
Notification Appliance Circuits – NACs (Available combinations shown at right)	Class B	4	2	2		0		2	0		Two Class B NACs
	Class A	0	1	1		2		0	1		
Power Supply		4.25 amps expandable to 7.0 amps					4.25 amps total				
Maximum NAC current		2.0 amps each, 3.5 amps total 7.0 amps w/ optional transformer					2.0 amps each, 3.5 amps total				
Base Panel Current Draw		Standby: 128 mA; Alarm: 242 mA					Standby: 104 mA; Alarm: 224 mA			Standby: 96 mA; Alarm: 180 mA	
Battery Placement		Holds up to 18 Ah (12V17A) batteries.					Holds up to 7 Ah (12V6A5) batteries.				
Auxiliary Current		0.5 amps max. May be programmed as resettable.									
Auxiliary Output		24 Vdc regulated									
Maximum number of detectors		30 detectors when using 500 & 700 series detectors									
IDC Alarm Current		3.0 mA (Consult detector compatibility list p/n 3100468 for maximum detectors per circuit)									
IDC Circuit		Maximum loop resistance: 13 Ohms; Maximum loop capacitance: 0.03 µF									
IDC Operating Voltage		16.9 to 29 Vdc									
Alarm, Trouble, Supervisory Contacts		Form "C" Contacts at 30 Vdc @ 1 A (resistive load)									
Terminals (wire gauge)		18 - 12 AWG (0.75 mm ² - 2.5 mm ²)									
Serial Communications Bus for Annunciators and Relay Modules		Maximum resistance: 13 Ohms; Maximum capacitance: 0.03 µF Up to 1,000 feet using 18 AWG, twisted wire required for Serial Communication. No T-tapping.									

Contact Information:

**Edwards
Signaling**

Quick Reference

Consult relevant literature for full listing of available models and options.

Control Panels	
E-FSC1004RD	Conventional Fire Alarm Control Panel with dialer, 10 Class B IDCs and 4 Class B NACs
E-FSC502RD	Conventional Fire Alarm Control Panel with dialer, 5 Class B IDCs and 2 Class B NACs
E-FSC302RD	Conventional Fire Alarm Control Panel with dialer, 3 Class B IDCs and 2 Class B NACs
F-TRIM10R	Semi-Flush Mount Trim Kit for E-FSC1004R
F-TRIM35R	Semi-Flush Mount Trim Kit for E-FSC502R and E-FSC302R
BC-1R	Battery Cabinet, red
12V6A5	7.2 Ah Batteries
12V10A	11.0 Ah Batteries
12V17A	18 Ah Batteries

Option Cards	
F-XTR120	Expander X-Former, 120 Vac, E-FSC1004RD only
CTM	City Tie Module (Requires 4" sq. box or 2-gang)
RPM	Reverse Polarity Module, Requires MFC-A or other listed FA enclosure
FSRRM24	Remote Relay Module – 5 Form C relays, Config. IDCs 1-5, or 6-10, or common system indicators, Requires MFC-A or other listed FA enclosure

Remote Annunciation	
FSRSI	Remote System Indicator – Power, Alarm, Super., Trouble, and Grnd LEDs (Single Gang trim included)
FSRZI-A	Remote Zone Indicator – 5 Red LEDs for 5 IDCs (Single Gang trim included)
FSRZI-SA	Remote Zone Indicator – 5 Bi-Color LEDs (Red/Yellow) for 5 IDCs (Single Gang trim included)
FSAT-2	Ann. Trim Plate, 2-Gang
FSAT3	Ann. Trim Plate, 3-Gang
FSRA10	Remote Annunciator 10-Zone Bi-Color LEDs (Red/Yellow) w/ System Indicators for E-FSC1004RD (4" sq. box mnt.)
FSRA10C	Remote Annunciator 10-Zone Bi-Color LEDs (Red/Yellow) w/ System Indicators & Controls for E-FSC1004RD (4" sq. box mnt.)
FSUIM	Graphic Drive/Interface providing System Indicators and Controls

Power Supplies	
EBPS6A	6.5 Amp Booster Power Supply
EBPS6A	6.5 Amp Booster Power Supply
EBPS10A	10 Amp Booster Power Supply
12V6A5	7.2 Ah Batteries
12V10A	11.0 Ah Batteries
BC-1R - Red	Battery Cabinet

2-Wire Detectors and Bases	
511C	Photoelectric Smoke Detector, Base included
521B	Photoelectric Smoke with CleanME Feature, Base included
TS7-2	Conventional photoelectric smoke detector, 6" 3-terminal base, 12/24VDC. 3-terminal base 701U.
TS7-2T	Conventional photoelectric smoke detector, FS & RoR heat, remote alarm/trouble LED., 12/24VDC.

Heat Detectors	
281B-PL	135" Fixed / RoR Heat Detector
282B-PL	194" Fixed / RoR Heat Detector
302-AW-135	135" Fixed / RoR Moisture Proof Heat Detector
302-AW-194	194" Fixed / RoR Moisture Proof Heat Detector

2-Wire Duct Detectors	
SD-2W	Conventional SuperDuct Detector
SD-Txx	Sampling Tubes for SuperDuct
SD-TRK4	Remote Test Stations for SuperDuct

Manual Stations	
278B-1110	Double Action Pull Station, Term., Tool Reset, Lexan
278B-1120	Double Action Pull Station, Term., Key Reset, Lexan
276B-RSB	Surface Mount Box, Red
MPSR1-	Weatherproof Manual Station,
S45W-GE	c/w backbox

Strobes, Horns	
EG1RF-VM	Wall Strobe, 15-110 cd, Marked "Fire", 24VDC, red
EG1RF-HDVM	Wall Horn/Strobe, 15-110 cd, Marked "Fire", 24VDC, red
EG1RF-HD	Wall Horn, Temporal, High/Low dB, Marked "Fire", 24VDC, Red
EG1RT	Genesis Trim Plate (for 2-gang or 4" sq. boxes), red
EGCF-VM	Ceiling Multi-cd Strobe, 15-95 cd, Marked "Fire", red
EGCF-VMH	Ceiling Multi-cd Strobe, 95-177 cd, Marked "Fire", red
EGCF-HDVM	Ceiling Multi-cd Horn-Strobe, 75-95 cd, Marked "Fire", red
EGCF-HDVMH	Ceiling Multi-cd Horn-Strobe, 95-177 cd, Marked "Fire", red
CS405-8A-T	Weatherproof Strobe, 110 cd
2452THS-110-R	Weatherproof Horn/Strobe, 110 cd
449	Weatherproof Box for CS405 strobes
2459WPB-R	Weatherproof Surface Box, red

Doorholders	
1501-AQN5	Single Door, Floor Mounted
1502-AQN5	Double Door, Floor Mounted
1504-AQN5	Long Catch Plate, Flush Wall Mnt.
1505-AQN5	Short Catch Plate, Flush Wall Mnt.
1508-AQN5	Surface, Wall Mounted

Relays	
MR101/C	Single SPDT relay. Contact Rating 10 Amps @ 115Vac and Coil Power 24 Vac, 24Vdc, 115Vac or 230Vac.
MR201/C	Single DPDT relay. Contact Rating 10 Amps @ 115Vac and Coil Power 24 Vac, 24Vdc, 115Vac or 230Vac.
PAM1	Encapsulated SPDT relay. Contact Rating 10 Amps @ 115Vac and Coil Power 24 Vac, 24Vdc, or 115Vac.

For complete product specifications and ordering information, see Data Sheet S85005-0126 – E-FSC Conventional Fire Alarm Control Panels.

Booster Power Supply

Consult relevant literature for application details.

NAC Class B wiring

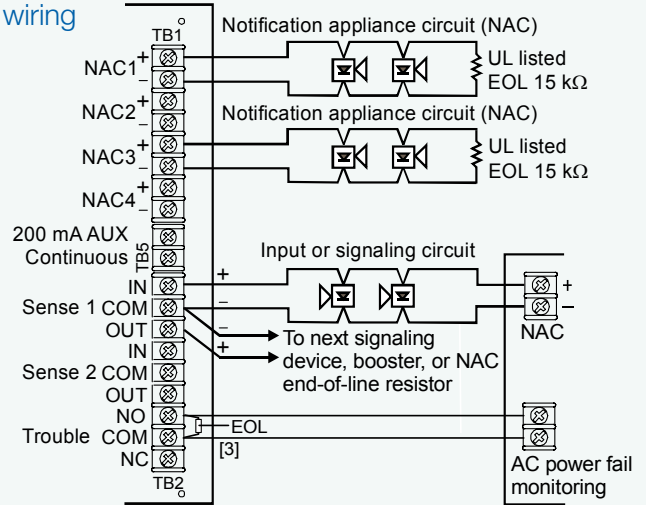

Specifications	EBPS6A - 6.5 amp Booster	EBPS10A - 10 amp Booster
AC Line Voltage	120VAC 50/60Hz 390 watts	120VAC 50/60Hz 580 watts
NAC Ratings	24Vdc nominal 6.5A max total all NACs	24Vdc nominal 10A max total all NACs
Trouble Relay	2 Amps @ 30Vdc	
Auxiliary Outputs	Four individually configurable outputs can replace NACs 1, 2, 3 or 4 as auxiliary outputs. 200 mA dedicated auxiliary for use with E-NAC module.	
Input Current	6mA @ 24Vdc (from an existing NAC)	
Current	70mA (Booster Internal Supervisory)	
Maximum Battery Size	10 Amp Hours (2 of 12V10A) in cabinet up to 24 Amp hours with external battery cabinet (p/n BC-1R)	
Paige Wire	Twisted nonshielded FPLP #14 AWG – 4719A or #12 AWG – 4725A (THHN or TFN in conduit can be used on NAC)	
Environmental	Temperature 32° to 120°F (0° to 49°C), Humidity 0 to 93% non condensing @ 32°C	
NAC Wiring	(4) Class B or (2) Class A	
Output Signal Rates	Continuous, 3-3-3 temporal, or follow installed panel's NAC.	

Annunciator Bus

Consult relevant literature for application details.

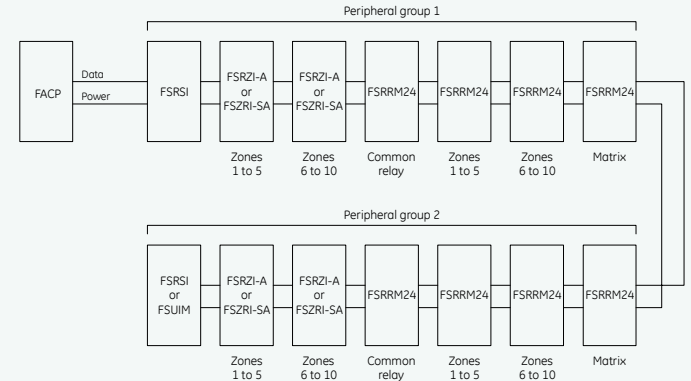

Notes

- Install only one FSRRM24 configured for common relay operation (jumper installed on JP5) per peripheral group.
- Install zone indicator modules only for zones 6 to 10 on ten-zone control panels.
- For ten-zone control panels, install an F-series remote annunciator in place of the FSRSI and the two zone indicator modules (FSRZI-A or FSZRI-SA).
- If the remote modules require more power than the control panel can provide, use a power-limited and regulated 24 VDC auxiliary/booster power supply that is UL/ULC Listed for fire protective signaling systems to power all or some of the remote modules.