



Genesis Speaker-Strobe Installation Sheet

Description

The Genesis Speaker-Strobe is a fire alarm notification appliance designed for indoor walls. See Table 1 for a list of model numbers.

Table 1: Models

Description	Number	
Speaker-Strobe, 25 VRMS, 15 to 110 multi-cd, white	ADTG4-S2VM	MG4-S2VM
	EG4-S2VM	XLSG4-S2VM
	G4-S2VM	ZG4-S2VM
Speaker-Strobe, 25 VRMS, 15 to 110 multi-cd, white, with FIRE marking	ADTG4F-S2VM	MG4F-S2VM
	EG4F-S2VM	XLSG4F-S2VM
	G4F-S2VM	ZG4F-S2VM
Speaker-Strobe, 70 VRMS, 15 to 110 multi-cd, white	ADTG4-S7VM	MG4-S7VM
	EG4-S7VM	XLSG4-S7VM
	G4-S7VM	G4-S7VM
Speaker-Strobe, 70 VRMS, 15 to 110 multi-cd, white, with FIRE marking	ADTG4F-S7VM	MG4F-S7VM
	EG4F-S7VM	XLSG4F-S7VM
	G4F-S7VM	ZG4F-S7VM
Surface mount box, white	ADTG4B	MG4B
	EG4B	XLSG4B
	G4B	ZG4B

The speaker-strobe includes field configurable switches for selecting the desired candela output and wattage tap. These settings lock in place and remain visible after final installation.

This strobe features an enhanced synchronization circuit to comply with the latest requirements of UL 1971 *Signaling Devices for the Hearing Impaired* and the latest Canadian standard CAN/ULC-S526. Synchronized operation requires a separately installed synchronization control module. See Table 2 for a list of compatible synchronization modules.

Install this device in accordance with applicable requirements in the latest editions of the NFPA codes and standards and *Canadian Electrical Code, Part 1*, Section 32 and CAN/ULC-S524, *Standard for the Installation of Fire Alarm Systems*, and in accordance with the local authorities having jurisdiction.

Table 2: Compatible synchronization module models

Description	Number	
Auto-sync output module	SIGA-CC1S	SIGA-MCC1S
	GSA-CC1S	GSA-MCC1S
Genesis signal master - remote mount	ADTG1M-RM	MG1M-RM
	EG1M-RM	XLSG1M-RM
	G1M-RM	ZG1M-RM

Installation

WARNING: To reduce the risk of shock, disconnect all power and allow 10 minutes for stored energy to dissipate before handling.

Caution: Electrical supervision requires the wire run to be broken at each terminal. Do not loop the signaling circuit field wires around the terminals.

To install the speaker-strobe:

1. Remove the cover by depressing the tabs on top of the unit by inserting a small screwdriver from the top and twisting slightly.
2. If temporal strobe (private mode) operation is desired, cut jumper JP1. See Figure 2.
3. Connect the speaker and strobe terminals to the signal circuit field wiring. For the unit to function properly, observe polarity. See Figure 5.
4. Slide the candela switch to the desired candela output (15, 30, 75, or 95 cd) by aligning it with the indicator below the switch. See Figure 1.
5. Slide the wattage switch to the desired wattage tap (2 W, 1 W, 1/2 W, or 1/4 W) by aligning it with the indicator below the switch. See Figure 1.
6. Mount the unit onto a compatible electrical box. See Figure 4.
7. Replace the cover by aligning it at the bottom and snapping it in at the top.
8. Test the unit for proper operation.

Figure 1: Field-configurable switches

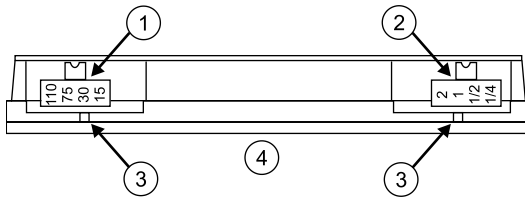

- 1. Candela switch
- 2. Indicator
- 3. Wattage switch
- 4. Bottom

Figure 2: Strobe settings

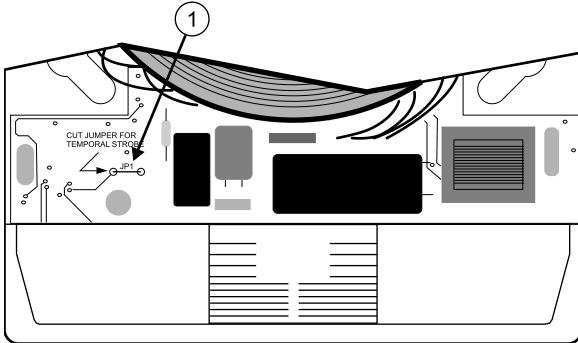

- 1. JP1: Strobe signal output: Cut to change from 1 flash per second (public mode) to temporal (private mode)

Note: If the strobe is set to temporal (private mode), this device is no longer UL 1971 or ULC-S526 Listed or FM Approved but is UL 1638 Listed.

Figure 3: UL 1971 minimum light output (% of rating vs. angle)

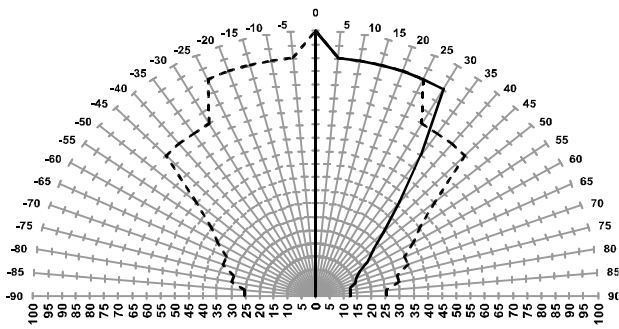

- 1. ■ ■ ■ ■ ■
- 2. —

- 1. Percentage of candela horizontal spec.
- 2. Percentage of candela vertical spec.

Figure 4: Mounting diagram

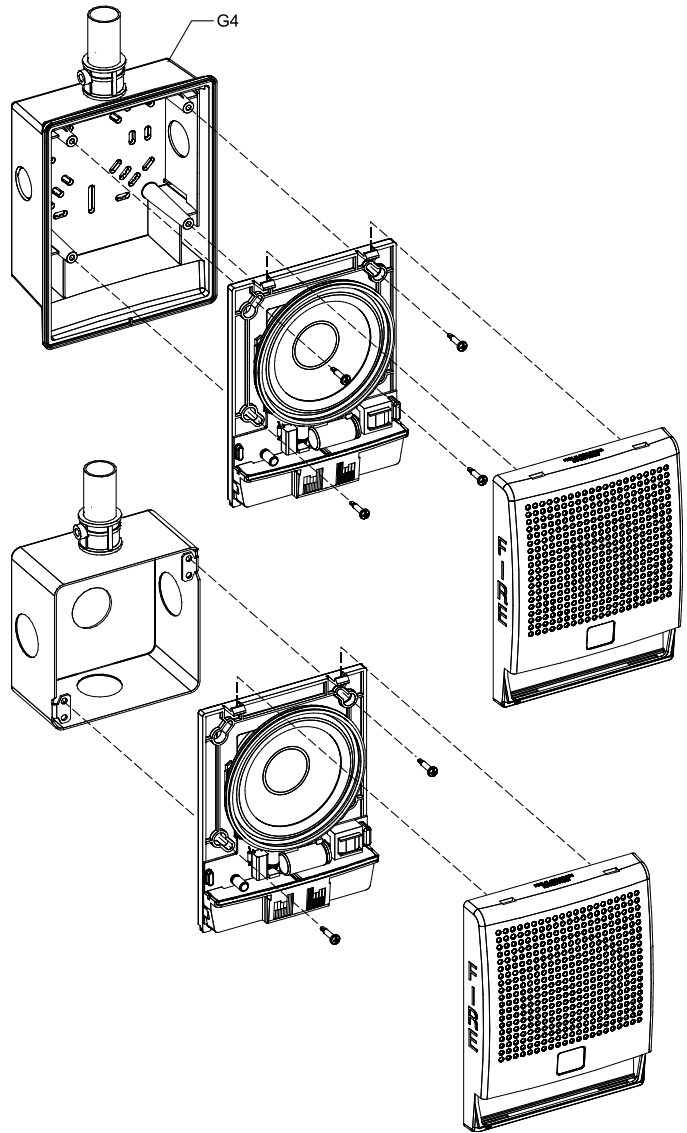
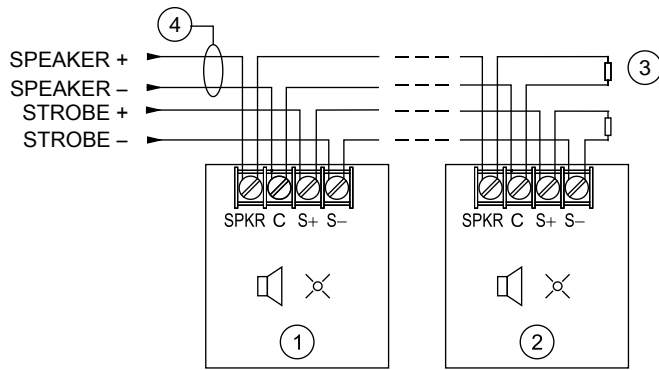

Figure 5: Wiring Diagram



1. First speaker-strobe
2. Last speaker strobe
3. EOL resistor, voltage determined by control panel
4. Amplifier output voltage must match the voltage ratings of the speaker (25 or 70 VRMS)

Note: Signal polarity is shown in the alarm condition.

Table 3: Strobe operating current in RMS (A)

	15 cd	30 cd	75 cd	110 cd
VDC	0.096	0.130	0.239	0.294
VFWR	0.120	0.169	0.329	0.375

VDC = Volts direct current, regulated and filtered

VFWR = Volts full wave rectified

Operating currents shown above were measured by UL at 16 VDC and 16 VFWR.

Table 4: Sound level output (dBA)

Wattage	Output
1/4 W	80
1/2 W	83
1 W	86
2 W	89

UL 1480: Sound level output at 10 ft (3.05 m) measured in a reverberant room using 400 to 4,000 Hz band limited pink noise.

ULC-S541: Meets or exceeds 85 dBA in an anechoic chamber at 10 ft (3.05 m).

Directional characteristics: Within 6 dB of on-axis sound level when measured 90° off-axis (horizontal).

Maintenance

This unit is not serviceable or repairable. Should the unit fail to operate, contact the supplier for replacement.

Perform a visual inspection and an operational test twice a year or as directed by the local authority having jurisdiction.

Do not change the factory-applied finish.

Specifications

Operating voltage	
Speaker	25 VRMS (model S2) or 70 VRMS (model S7)
Strobe	24 VDC, 24 VFWR
Supervisory voltage	30 V maximum
Strobe operating current	See Table 3
Sound level output	See Table 4
Speaker response	400 to 4,000 Hz
Light output	Selectable at 15, 30, 75, and 110 cd
Default settings	1 flash per second (fps)
Wire size	12 to 18 AWG (0.75 TO 2.50 mm ²)
Compatible electrical boxes	North American 4 in. square electrical box, 2-1/8 in. deep (no extension ring) G4 Series surface mount box: See Table 1
Operating environment	
Temperature	32 to 120°F (0 to 49°C)
Relative humidity	0 to 93% noncondensing
Intended Installation	Indoor dry

Regulatory information

Manufacturer	Edwards, A Division of UTC Fire & Security Americas Corporation, Inc. 8985 Town Center Parkway, Bradenton, FL 34202, USA
Year of manufacture	The first two digits of the DATE MFG number (located on the product identification label) are the year of manufacture
UL/ULC rating	Regulated 24 DC and 24 FWR This device was tested to the regulated 24 DC/FWR operating voltage limits of 16 V and 33 V. Do not apply 80% and 110% of these values for system operation.
Environmental class	UL: Indoor
Synchronization	Meets UL 1971 requirements. Maximum allowed resistance between any two devices is 20 Ω. Refer to specifications for the synchronization control module, this strobe, and the control panel to determine allowed wire resistance.
Agency listings	UL 1638, UL 1480, and UL 1971 CAN/ULC S526, ULC-S541 BS EN 60065:2002 [1]

[1] Nameplate marking is located on the inside surface of the device.

Contact information

For contact information, see www.edwardsutcfs.com.

