

SuperDuct Conventional Two-Wire Duct Smoke Detector

Product description

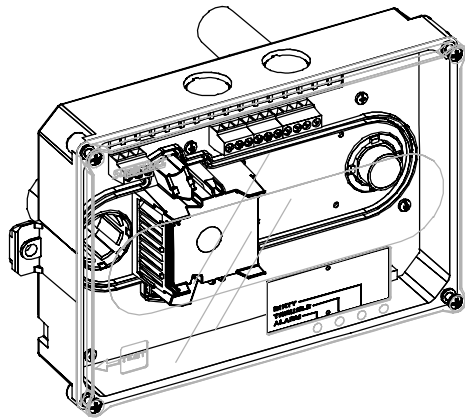

The SuperDuct Conventional Two-Wire Duct Smoke Detector detects the presence of smoke in a building's HVAC system under extended temperature ranges. Its primary purpose is to provide early warning of an impending fire and to prevent smoke from circulating throughout the building.

The duct smoke detector provides a Form C alarm relay that changes over when the detector enters the alarm state. Operation of the alarm relay can't be guaranteed when installed on the same circuit as other automatic or manual initiating devices.

The duct smoke detector comprises a plastic housing, a printed circuit board, a clear plastic cover, and an exhaust tube. The clear plastic cover permits visual inspections without having to disassemble the detector. The cover attaches to the detector housing using four captive screws and forms an airtight chamber around the sensing electronics.

A sampling tube is required to introduce air into the detector. The sampling tube is ordered separately and varies in length depending on the width of the HVAC duct.

This document applies to the following duct smoke detector models: ESD-2W and SD-2W.

WARNING: SuperDuct duct smoke detectors are not intended as substitutes for open area protection.

Related documents

For information regarding duct smoke detector installation, testing, and maintenance not included in this installation sheet, refer to Technical Bulletin P/N 3100737.

Specifications

Dimensions: 8.70 x 5.45 x 1.90 inches
Wire size: 14 to 22 AWG
Smoke detection method: Photoelectric (light scattering principle)
Air velocity rating: 100 to 4,000 ft/min
Air pressure differential: 0.005 to 1.00 inches of water
Sensitivity: 0.79 to 2.46 %/ft obscuration
Reset time: 1 second, max.
Power up time: 30 seconds, max.
Alarm test response time: 5 seconds
LED indicators: Alarm (red), Trouble (yellow), Dirty (yellow)
Zone alarm relay
Unsupervised and power-limited

Quantity: 1
Type: Form C
Ratings: 2.0 A at 30 Vdc (resistive)
Detector operating voltage: 16 to 30 Vdc
Detector operating current
Startup: 200 μ A
Standby: 70 μ A
Alarm: 5 to 100 mA
Alarm impedance: 50 to 750 Ω
Accessory operating voltage: 3.3 Vdc, minimum
Accessory operating current: 1.5 mA, minimum
Operating environment
Temperature (UL): -29 to 70 °C (-20 to 158 °F)
Temperature (ULC): -29 to 49 °C (-20 to 120.2 °F)
Humidity (UL and ULC): 93% RH, noncondensing
Compatibility ID
0.0: IDC short circuit current \leq 100 mA
1.0: IDC short circuit current $>$ 100 mA

Compatible fire alarm control panels

Compatibility ID 0.0 and 1.0

Manufacturer	Model	Maximum detectors
EST	EST3 with 3-IDC8/4	42 per IDC

Note: Refer to your fire alarm control panel's documentation for additional system compatibility information.

Duct smoke detector limitations

SuperDuct duct smoke detectors will not operate without electrical power.

SuperDuct duct smoke detectors will not operate as designed outside of the listed electrical and environmental specifications.

SuperDuct duct smoke detectors will not sense smoke unless the ventilation system is operating and the sensor's cover is properly installed.

SuperDuct duct smoke detectors may not operate as designed unless installed in accordance with these instructions and all applicable national and local codes as determined by the local authority having jurisdiction.

SuperDuct duct smoke detectors may not be installed on circuits that use alarm verification.

Installation guidelines

Install the duct smoke detector on a flat section of HVAC duct between six and ten duct widths from any bends or obstructions.

Install supply-side detectors at a point downstream from the supply fan and after the air filter.

Install return-side detectors at a point before the return air stream is diluted by outside air.

Sampling tubes must extend at least two-thirds across the width of the duct. Sampling tubes longer than 36 inches must be supported securely at both ends.

Installation instructions

Please read these instructions thoroughly before installing. In addition to this document, important information can be found in Technical Bulletin P/N 3100737.

Step 1: Verify the duct air velocity

Drill a small hole at the point where the duct smoke detector is being installed. Using the SD-VTK Air Velocity Test Kit and a suitable air velocity meter, verify that the air velocity in the HVAC duct falls within the specified operating range of the detector and note which direction the air flows.

If the air velocity does not fall within the specified range, relocate the detector and seal the hole in the HVAC duct.

Note: In order to verify airflow direction and velocity, air must be moving through the HVAC system.

Step 2: Drill the mounting holes

Attach the drill template to the HVAC duct. Drill (or punch) the mounting holes where indicated. Remove any rough edges from the holes.

Step 3: Assemble the detector

Assemble the duct smoke detector as shown in Figure 1. Rotate the air sampling tube so the inlet holes face the direction of airflow.

Note: In some applications, it may be desirable to install the sampling tube through the front of the detector. For details, refer to Technical Bulletin P/N 3100737.

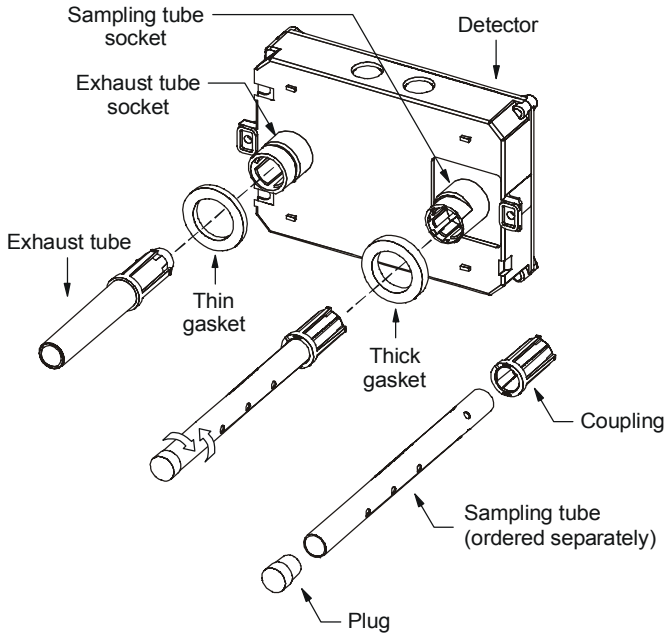

Figure 1: Detector assembly diagram

Sampling tubes must extend at least two-third across the width of the duct and must be supported at the far end if longer than 36 inches. Sampling tubes are available in the lengths listed below.

Model	Description
SD-T8	8-inch sampling tube
SD-T18	18-inch sampling tube
SD-T24	24-inch sampling tube
SD-T36	36-inch sampling tube
SD-T42	42-inch sampling tube
SD-T60	60-inch sampling tube
SD-T78	78-inch sampling tube
SD-T120	120-inch sampling tube

Note: For duct widths greater than 36 inches, use a sampling tube that is longer than the width of the duct (see Figure 3).

Step 4: Mount the detector

Mount the duct smoke detector on the HVAC duct as shown in Figure 2. Secure the detector using the two sheet metal screws provided in the hardware kit.

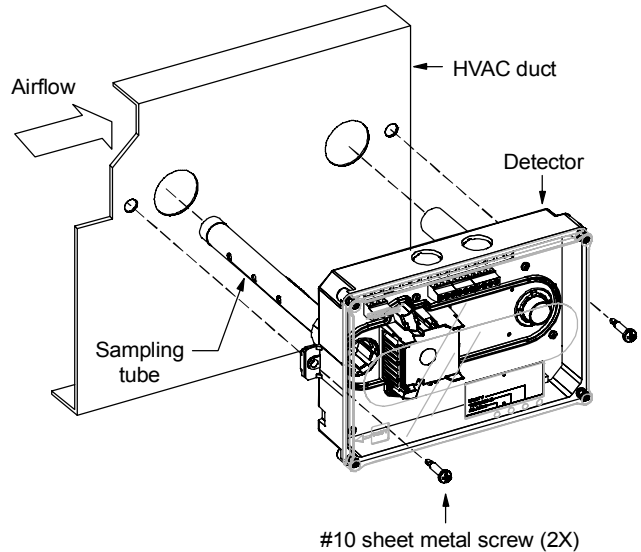

Figure 2: Detector installation diagram

If the sampling tube is longer than the width of the duct, drill a 3/4-inch hole on the opposite side of the duct. Extend the sampling tube through the hole as shown in Figure 3 and seal the opening around the tube with an approved sealant.

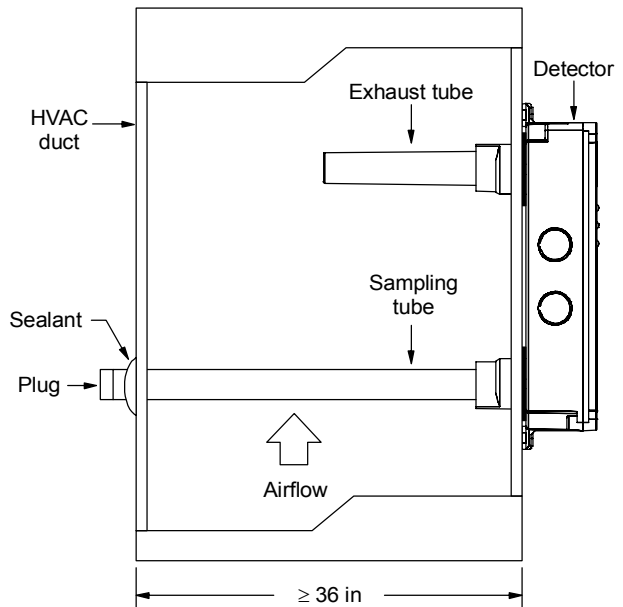

Figure 3: Installation with sampling tubes longer than the width of the duct

Step 5: Verify the air pressure differential

Open the duct smoke detector and connect a suitable air pressure differential meter to the sampling tube and exhaust tube openings as shown in Figure 4. Verify that the air pressure differential measured between the two openings falls within the specified operating range of the detector.

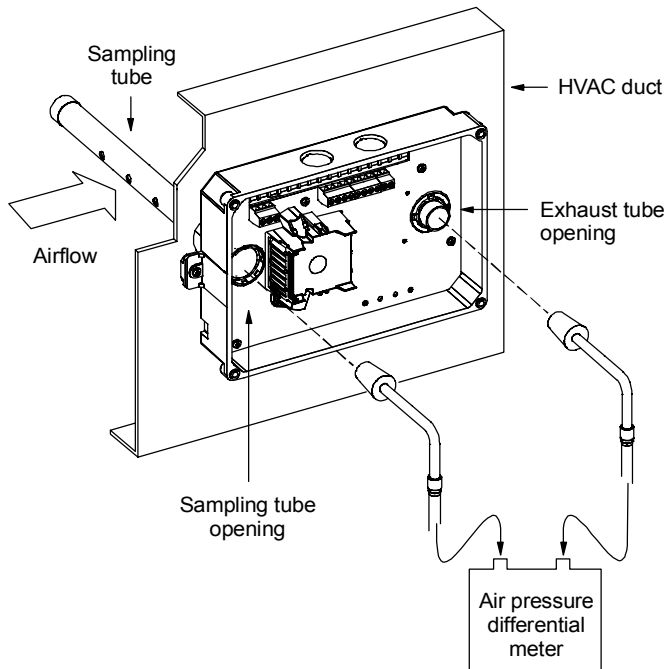

Figure 4: Air pressure differential measurement

Note: To measure air pressure differential, you must have a suitable air pressure differential meter (supplied by the installer) and an SD-VTK Air Velocity Test kit.

Wiring

Determine the short circuit current specification of the control panel's initiating device circuit (IDC) then wire the duct smoke detector as shown in Figure 5 or Figure 6.

Caution: Wiring the incorrect terminals to the initiating device circuit can cause equipment damage.

Testing

After completing the installation, test the duct smoke detector to ensure that it is operating correctly before leaving the site. For details, refer to Technical Bulletin P/N 3100737.

Notes

[1] End-of-line resistor is required on the last detector only. The value is determined by the fire alarm control panel's initiating device circuit.

[2] No more than one remote test station can be connected at the same time. Wiring is unsupervised. Maximum wire resistance is 10 ohms per wire.

[3] Only the first detector to go into alarm operates its alarm relay. Operation of the alarm relay can't be guaranteed if a manual initiating device on the same circuit is activated.

Initiating device circuit on UL/ULC listed fire alarm control panel

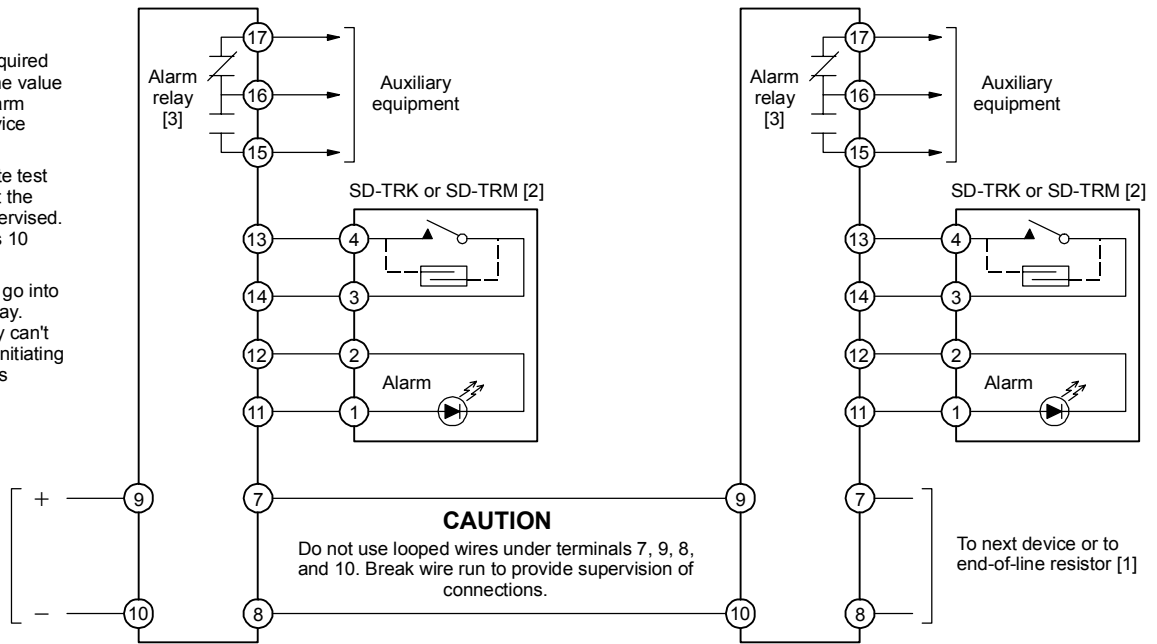

Figure 5: Installation wiring diagram (IDC short circuit current $\leq 100\text{ mA}$)

Notes

[1] End-of-line resistor is required on the last detector only. The value is determined by the fire alarm control panel's initiating device circuit.

[2] No more than one remote test station can be connected at the same time. Wiring is unsupervised. Maximum wire resistance is 10 ohms per wire.

[3] Only the first detector to go into alarm operates its alarm relay. Operation of the alarm relay can't be guaranteed if a manual initiating device on the same circuit is activated.

Initiating device circuit on UL/ULC listed fire alarm control panel

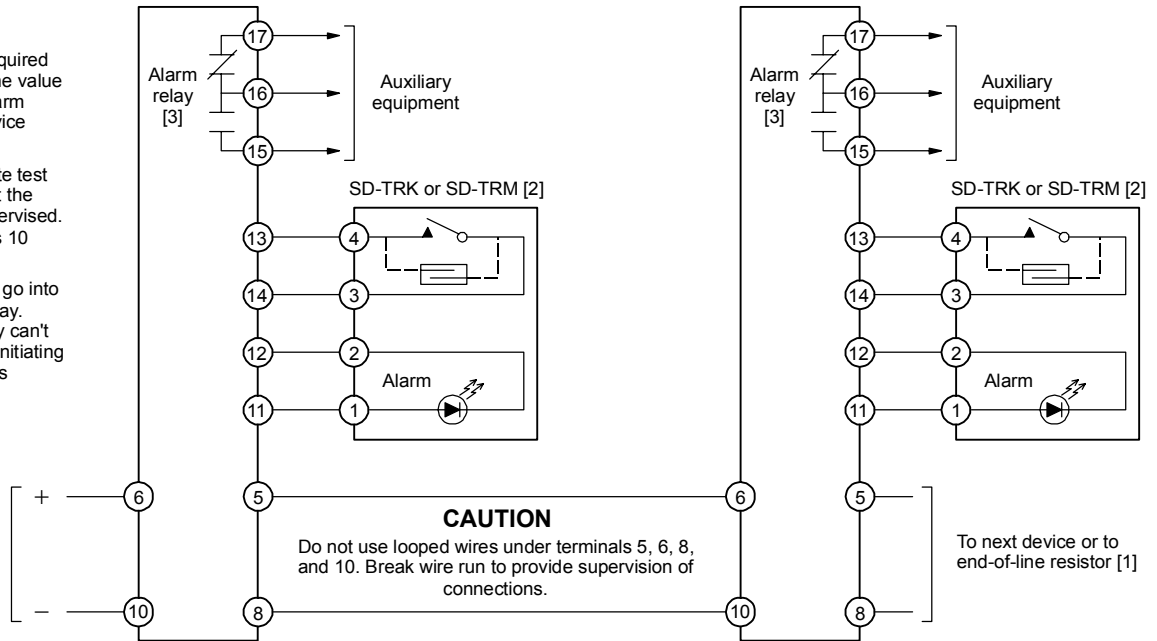

Figure 6: Installation wiring diagram (IDC short circuit $> 100\text{ mA}$)