

# FX-2WIRE Analog Class A-B Two-Wire Module Installation Sheet

## Operation

The FX-2WIRE module is designed to interface between compatible conventional two-wire smoke detectors and a control panel. It monitors the circuit and smoke detectors and signals the control panel of any trouble or alarm conditions. The module also regulates and supervises the 24 VDC input power.

The module is configured from the factory to operate as a two-wire alarm device that does not require alarm verification. It can be configured for two-wire alarm verified operation through front panel programming or the configuration utility. When using the alarm verification feature of the control panel, do not mix normally open contact initiating devices with two-wire conventional smoke detectors.

The module recognizes the CleanMe signal from detectors that support this feature.

The module device address is set using the two rotary switches located on the front of the module. One device address is required.

The device can be set for Class B or Class A operation using the slide switch located on the front of the module.

**Caution:** This module cannot be used on a device loop with isolator modules or isolator bases.

## Slide switch operation

The following slide switch settings determine the operation of the module. Setting the initial slide switch position is generally performed during module installation. This setting can be changed while the system is operating, but the change must be confirmed through front panel programming or using the configuration utility.

**Table 1: Slide switch operation**

| Setting | Operation | Device type description [1]   |
|---------|-----------|---|
| 1       | Class B   | Class B 2-wire smoke non-verified: Configures the module to monitor two-wire conventional smoke detectors (that do not require alarm verification) and normally open contact initiating devices on a Class B circuit. |
| 2       | Not used  |   |
| 3       | Class A   | Class A 2-wire smoke non-verified: Configures the module to monitor two-wire conventional smoke detectors (that do not require alarm verification) and normally open contact initiating devices on a Class A circuit. |

[1] Additional device types are available through front panel programming or the configuration utility. Refer to applicable control panel technical reference manual.

**Figure 1: Slide switch**

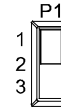

## LED operation

The module provides a bicolor LED that shows its status.

Normal: Green LED flashes

Alarm/active: Red LED flashes

## Installation

Install and wire this device in accordance with applicable national and local codes, ordinances, and regulations.

**WARNING:** This module will not operate without electrical power. As fires frequently cause power interruption, you should discuss further safeguards with your local fire protection specialist.

**Note:** The module is shipped from the factory as an assembled unit; it contains no user-serviceable parts and should not be disassembled.

## To install the module:

1. Verify that all field wiring is free of opens, shorts, and ground faults.
2. Make all wiring connections as shown in "Wiring" and in Figure 4.
3. Set the module address. Refer to the panel technical reference manual for a list of valid addresses.

Use a screwdriver to adjust the two rotary switches on the front of the module. Set the TENS rotary switch (0 through 12) for the 10s and 100s digit and the ONES rotary switch for the 0 through 9 digit. For example: device address 21, set TENS rotary switch to 2 and set the ONES rotary switch to 1 (see Figure 2).

4. Set slide switch P1 to appropriate setting. Refer to "Operation."
5. Mount the module on the electrical box using screws provided with the electrical box.
6. Mount the wall plate on the module using the hardware shown in Figure 3.

**Figure 2: Module address**

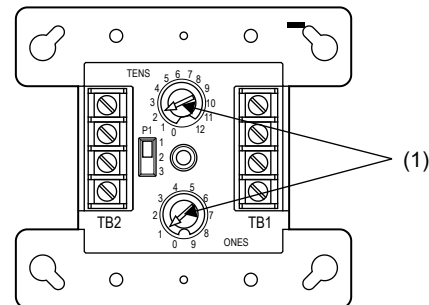

(1) Insert screwdriver here



**Figure 3: Module installation**

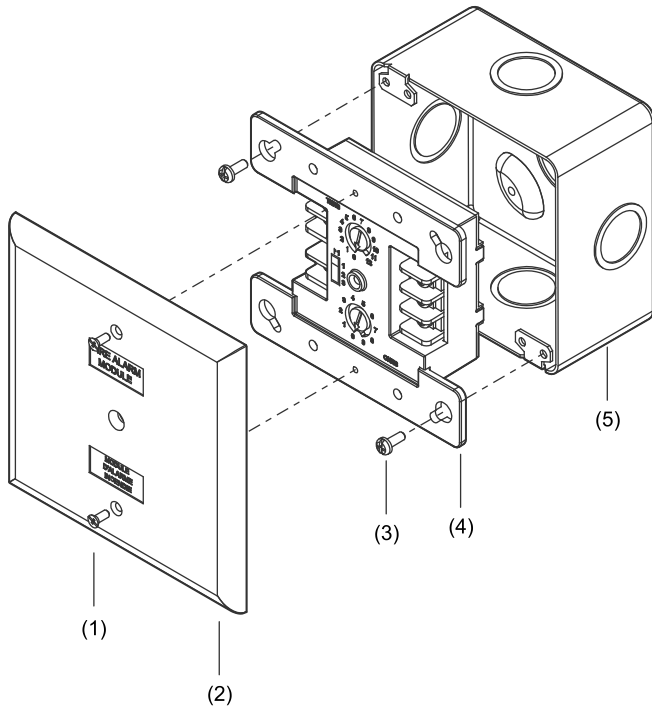

- (1) Cover plate plastite screws (2X)
- (2) Wall plate
- (3) Screw
- (4) Module
- (5) Compatible electrical box

### Wiring

Wire the device as shown in Figure 4. Be sure to observe the polarity of the wires.

Refer to the control panel technical reference manual for wiring specifications.

**Figure 4: Module wiring**

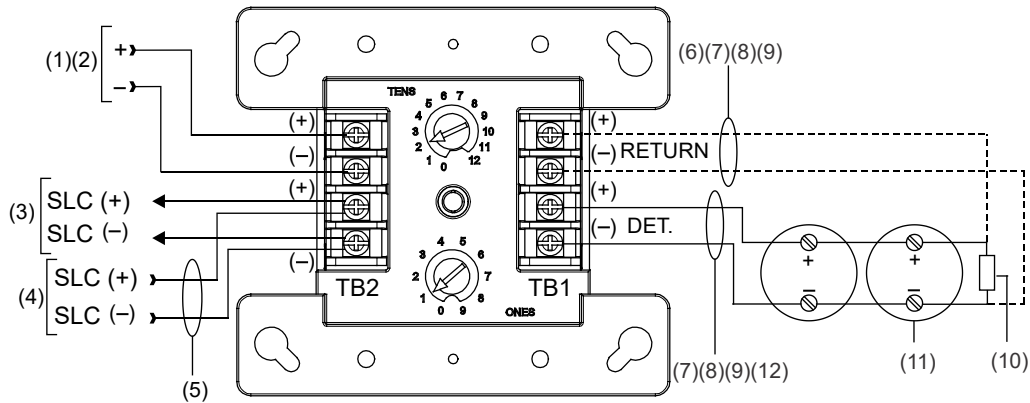

- (1) From control panel (non-resettable)
- (2) Class B Detector power
- (3) To next device
- (4) From previous device
- (5) Class A or Class B
- (6) Class A
- (7) Maximum 25 Ω resistance per wire
- (8) Maximum 12 AWG wire; minimum 18 AWG wire
- (9) Maximum 23.8 VDC at 35 mA
- (10) 4.7 kΩ EOLR used for Class B only
- (11) Typical initiating device
- (12) Class B

### Contact information

For contact information, see [www.kidde-esfire.com](http://www.kidde-esfire.com).

### Specifications

|  |  |
|--|--|
| Communication line voltage                 | Maximum 20.6 V peak-to-peak  |
| Current                                    |  |
| Standby                                    | 350 μA   |
| Activated                                  | 350 μA   |
| Control panel input power (not resettable) | 12.4 to 28.3 VDC   |
| Smoke power current                        |  |
| Standby                                    | 17 mA  |
| Alarm                                      | 58 mA  |
| Smoke detector current                     | 3 mA   |
| UL compatibility ID                        | 0.0  |
| Ground fault impedance                     | 5 kΩ   |
| Operating environment                      |  |
| Temperature                                | 32 to 120°F (0 to 49°C)  |
| Relative humidity                          | 0 to 93% noncondensing at 90°F (32°C)  |
| Storage temperature range                  | -4 to 140°F (-20 to 60°C)  |
| Compatible electrical boxes                | North American 4 inch square × 2-1/2 in. (64 mm) deep 2 gang box<br>Standard 4 in. square box 1-1/2 in. (38 mm) deep |
| Wire size                                  | 12, 14, 16, or 18 AWG wire (2.5, 1.5, 1.0, or 0.75 mm <sup>2</sup> ) (Sizes 16 and 18 AWG are preferred)             |
| Initiating device circuit (IDC)            |  |
| EOL resistor value                         | 4.7 kΩ, (P/N: EOL-4.7)   |
| Max. circuit resistance                    | 50 Ω (25 Ω per wire)   |
| Max. circuit capacitance                   | 0.1 μF   |