



# FX-IDCWS Analog Dual Input Waterflow - Supervisory Module Installation Sheet

## Operation

The module is an analog addressable device used to connect normally open waterflow alarm and supervisory initiating device circuits (IDCs) to a control panel. This module is designed for Class B circuit operation.

The device address is set using the two rotary switches located on the front of the module. Two consecutive device addresses are required. The second device address is automatically assigned one number higher than the value set on the rotary switches.

The module can operate in the following modes.

**Table 1: Module operation**

Operation	Device type description
Waterflow	Alarm latching delayed: Configures the module for use with only nonretarded waterflow alarm switches. When the NO input contact of an initiating device is closed, an alarm is sent to the control panel, which after a 16 second time delay, generates an alarm signal.
Supervisory	Supervisory active nonlatching US marketplace Supervisory active latching Canadian marketplace  Nonlatching: Configures the module for normally open dry contact initiating devices. When the NO input contact of an initiating device is closed, a supervisory signal is sent to the control panel and the supervisory condition is not latched at the module.  Latching: Configures the module for normally open dry contact initiating devices. When the NO input contact of an initiating device is closed, a supervisory signal is sent to the control panel and the supervisory condition is not latched at the module.

## LED operation

The module provides a bicolor LED that shows its status.

Normal: Green LED flashes

Alarm/active: Red LED flashes

## Installation

Install and wire this device in accordance with applicable national and local codes, ordinances, and regulations.

## WARNINGS

- This module will not operate without electrical power. As fires frequently cause power interruption, you should discuss further safeguards with your local fire protection specialist.
- This module does not support conventional smoke detectors.

**Note:** The module is shipped from the factory as an assembled unit; it contains no user-serviceable parts and should not be disassembled.

## To install the module:

- Verify that all field wiring is free of opens, shorts, and ground faults.
- Make all wiring connections as shown in "Wiring" and Figure 3.
- Set the module address. Refer to the panel technical reference manual for a list of valid addresses.

Use a screwdriver to adjust the two rotary switches on the front of the module. Set the TENS rotary switch (0 through 12) for the 10s and 100s digit and the ONES rotary switch for the 0 through 9 digit. For example: device address 21, set TENS rotary switch to 2 and set the ONES rotary switch to 1 (see Figure 1).

- Mount the module on the electrical box using screws provided with the electrical box.
- Mount the wall plate on the module using the hardware shown in Figure 2.

**Figure 1: Module address**

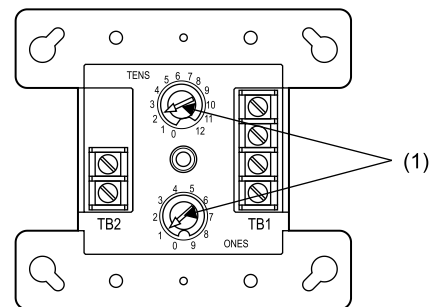

(1) Insert screwdriver here

**Figure 2: Module installation**

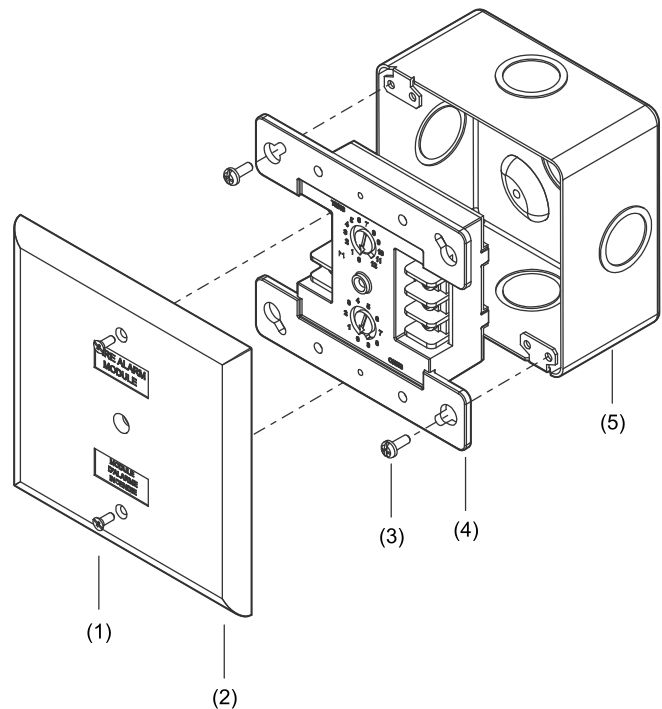

- (1) Cover plate plastite screws (2X)
- (2) Wall plate
- (3) Screw
- (4) Module
- (5) Compatible electrical box



## Wiring

Wire the device as shown in Figure 3. Be sure to observe the polarity of the wires.

- This module does not support two-wire smoke detectors.
- All wiring is power-limited and supervised.
- Refer to the control panel technical reference manual for wiring specifications.

## Specifications

Communication line voltage	Maximum 20.6 V peak-to-peak
Current	
Standby	550 $\mu$ A
Activated	725 $\mu$ A
Ground fault impedance	10 k $\Omega$
Operating environment	
Temperature	32 to 120°F (0 to 49°C)
Relative humidity	0 to 93% noncondensing at 90°F (32°C)
Storage temperature range	-4 to 140°F (-20 to 60°C)
Compatible electrical boxes	North American 4 inch square $\times$ 2-1/2 in. (64 mm) deep 2 gang box Standard 4 in. square box 1-1/2 in. (38 mm) deep
Wire size	12, 14, 16, or 18 AWG wire (2.5, 1.5, 1.0, or 0.75 mm <sup>2</sup> ) (Sizes 16 and 18 AWG are preferred)
Initiating device circuit (IDC)	
EOL resistor value	47 k $\Omega$ , (P/N: EOL-47)
Max. circuit resistance	50 $\Omega$ (25 $\Omega$ per wire)
Max. circuit capacitance	0.1 $\mu$ F

Figure 3: Module wiring

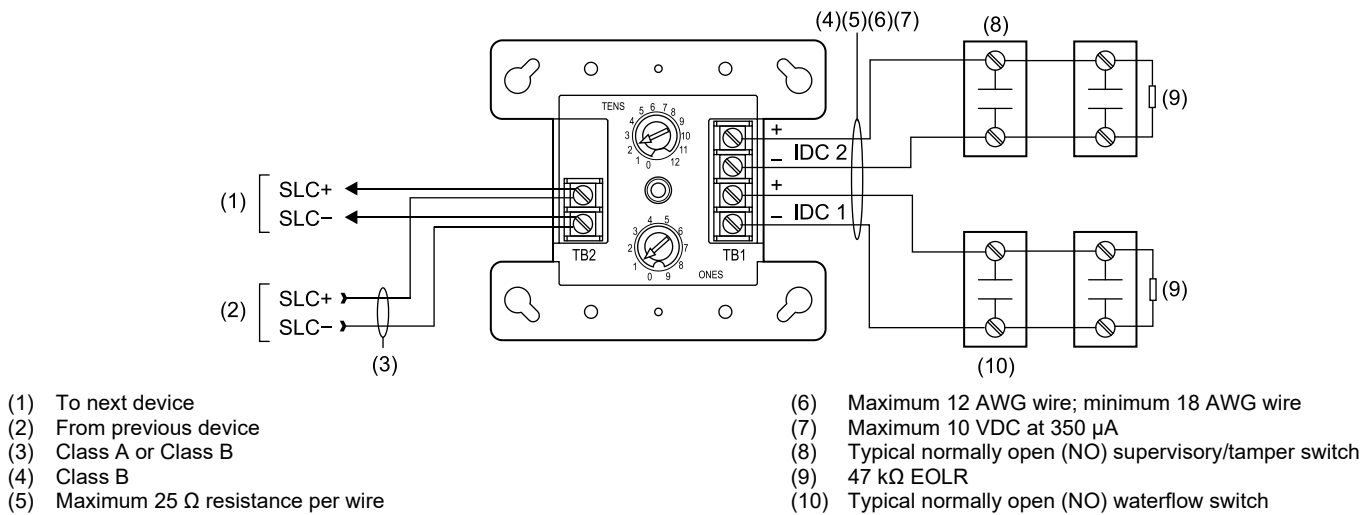

## Contact information

For contact information, see [www.kidde-esfire.com](http://www.kidde-esfire.com).