



2098-9201, -9203, & -9208 Photoelectric Detectors, 2098-9202 Photo w/Heat Detector, and 2098-9576 Ionization Detector Installation Instructions

GENERAL INFORMATION

Before installing these detectors, make a survey of the area to be covered in accordance with information provided in NFPA 72 E, Sections 4-1 through 4-6 (an overview of which is provided below). For specific applications, refer to Simplex publication "Common Code Requirements For Fire Alarm Systems" — Publication No. FA2-91-010. For additional information, refer to NFPA 72 E and the NEMA Guide For Proper Use of System Smoke Detectors.

SPECIAL CONSIDERATIONS

- Is there human occupancy?
- Contents to be protected.
- Type of construction and use.
- Burning characteristics of contents.
- Air movement - stratification.
- Deflections and obstructions.
- Height of ceilings.
- Surface conditions of ceilings.
- Type of ceiling construction.
- Total area.
- Vent locations - velocities - dilution.

APPLICATIONS

Each detector is capable of providing from 450 to 900 square feet (42 to 84 square meters) of coverage, depending on:

1. Requirements of local codes.
2. Results of engineering evaluation.
3. Physical characteristics of protected area.

Examples:

- a. Smooth, flat ceiling
 - Detectors may be spaced 30 feet (9 meters) apart.
- b. Ceiling divided by beams of more than 18 in. (46 cm) depth
 - At least one detector will be required in the space between every two beam.
- c. Ceiling divided by beams of more than 8 in. (20 cm) but less than 18 in. (46 cm) depth
 - Reduce the coverage area for each detector, and mount the detector to the bottom of the beams.

Important

Smoke must enter the chamber of the detector. Thus, air flow, air stratification, air velocity, air stagnation, and air migration will affect detector efficiency. Therefore:

- Do not install detectors in areas where temperatures are likely to exceed 100°F (38°C) or fall below 32°F (0°C).
- Do not install detectors on a ceiling within 4 inches (10 cm) of a wall.
- Do not install detectors where forced air ventilation may dilute the smoke before it reaches the detector.
- Do not install detectors in areas where smoke is normally present (kitchens, furnace rooms, laundry rooms, loading docks, rooms with fireplaces, rooms with candles, soldering rooms, etc.).

Suffix "C" following an 8-digit Product ID number denotes ULC-listed product.

- Do not install detectors in areas where there is likely to be steam (in hospital patient rooms with vaporizers, near shower rooms, above large sinks, etc.).
- Do not install detectors above ashtrays in elevator lobbies.
- Wall-mounted detectors should be located 4 to 12 inches (10-30.5 cm) from the ceiling to detector head.
- Protect all detector heads during construction to avoid infiltration of construction debris!

MAINTENANCE

The minimal requirement for detector maintenance should consist of cleaning surface dust by using a vacuum cleaner. Cleaning programs should comply with NFPA and local environments. Cleaning of the internal chamber should be done by Simplex technical representative only.

TEST EQUIPMENT AVAILABLE

2098-9822 (553-394) Extendable Smoke Generator

2098-9809 (553-533) Sensitivity Tester

2098-9814 (553-536) Test and Removal Tool (for use with 2098-9201, -9202, -9203, & -9576)

2098-9815 (553-553) Test and Removal Tool Holder (for use with 553-536 & 553-574)
(553-574) Test and Removal Tool (for use with 2098-9208)

TESTING

Before testing, disconnect city, release devices, and extinguish systems. Notify all appropriate personnel of test. The preferred test is with smoke using a 553-394 Extendable Smoke Generator. If this method is not acceptable or practical, a functional test can be performed by using a Test and Removal Tool. To test the detector, place the test tool around the detector body. This will alarm the detector. To clear the detector, remove the test tool and reset the fire alarm panel.

TABLE 1

SPECIFICATIONS	SMOKE DETECTOR DATA				
Detector	2098-9576	2098-9201	2098-9202	2098-9203	†2098-9208
Type of Detector	Ionization	Photoelectric	Photoelectric with Heat	Photoelectric	Photoelectric
Working Voltage (2-Wire)	15-36.3 VDC	15-36.3 VDC	15-36.3 VDC	15-36.3 VDC	15-32 VDC
Rated Voltage (4-Wire)	17.7-33.0 VDC	17.7-33.0 VDC	17.7-33.0 VDC	17.7-33.0 VDC	17.7-33.0 VDC
Voltage Waveform	Filtered DC * 18V Ripple Max.	Filtered DC * 18V Ripple Max.	Filtered DC * 18V Ripple Max.	Filtered DC * 18V Ripple Max.	Filtered DC † 18V Ripple Max.
Max. Alarm Current	86 mA	86 mA	86 mA	86 mA	86 mA
Surge Current	200 uA	200 uA	200 uA	200 uA	200 uA
Standby Current	40 uA	40 uA	40 uA	40 uA	50 uA
Heat Element Rating	N/A	N/A	135 Degrees F	N/A	N/A
** Compatibility Identifier	2098-9576	2098-9201	2098-9202	2098-9203	2098-9208
Test Procedure	Magnet or 553-536	Magnet or 553-536	Magnet or 553-536	Magnet or 553-536	Magnet or 553-574
Max. Qty. Per Initiating Circuit	See Table 4	See Table 4	See Table 4	See Table 4	See Table 4

† **CAUTION:** Do not use the 2098-9208 detector with the 2098-9734 power pack. The 2098-9208 does not operate from a full wave, rectified (unfiltered) DC power source.

* When using 2098-9536 four-wire base, full wave, rectified DC can be used.

** Compatibility identifier is the PID (model number) found on the panel or module and detector base.

TABLE 2

BASE	BOX MOUNTING		
	3 1/2" OCTAGONAL	4" OCTAGONAL	4" SQUARE
2098-9211	Yes	Yes	Yes
2098-9637	Yes	Yes	Yes
2098-9536	Yes	Yes	No

4" (10.16 CM) Octagonal Outlet Box
Not Furnished by Simplex Wire per NEC Article 370

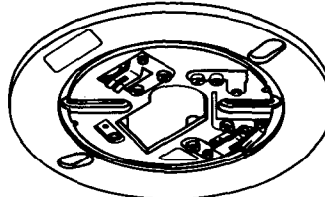
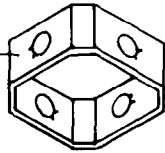

Base
2098-9211

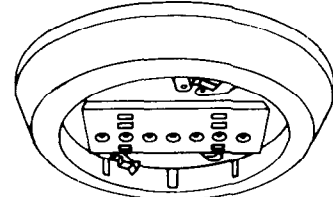

Base
2098-9536

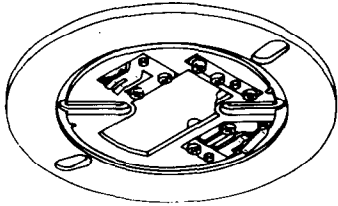

2098-9637
Base

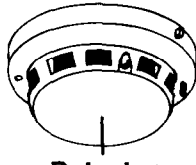

Detector
2098-9201,
2098-9203,
OR
2098-9576

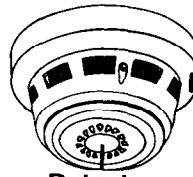

Detector
2098-9202

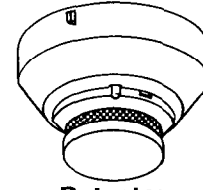

Detector
2098-9208

TABLE 3

INITIATING CIRCUITS OR PANEL PID (MODEL NO.)
2120-7012
2120-7013
2120-7014
2120-7015
2120-7019
2120-7023
2120-7024
2120-7031
2120-7032
2120-7033
4002-5001
4002-5002
4002-5003
4002-5004
4020-0305
4020-7003
4100-5001
4100-5002
4100-5011
4100-5012

TABLE 4

DETECTOR HEADS	COMPATIBLE 2-W BASE	MAX. QTY. OF BASES PER INITIATING CIRCUIT
2098-9201, 2098-9202, 2098-9203, 2098-9208, or 2098-9576	2098-9211 or 2098-9211 with 2098-9738 or 2098-9827	30 (See Table 3 and Note 5)
	2098-9637 or 2098-9637 with 2098-9738 or 2098-9827	1 (See Note 1)
	2098-9637 or 2098-9637 with 2098-9738 or 2098-9827	30 (See Table 3 and Note 5)
	2098-9637 with 2098-9738 or 2098-9827	1 (See Note 1)

Notes

1. Relay operation cannot be guaranteed unless it is the only device on that zone.
2. Panel compatibility identification marker is the model number of the module or panel.
3. Detector compatibility identification marker is the model number found on the detector label.
4. For detailed interconnection data, see wiring diagrams in Document 841-687.
5. Exceptions for the maximum quantity of 30 bases per initiating circuit are as follows:

Initiating Circuit	Qty. of Bases
2120-0523	20
2120-0527	20
2120-7011	18
2120-7022	18
2120-7805	25
2120-7806	25
4001-9403	18
4001-9404	18
4001-9813	18

WARNING

Red-labeled detector heads *MUST* only be used with red-labeled bases. Use in any other base will result in a non-functioning detector.

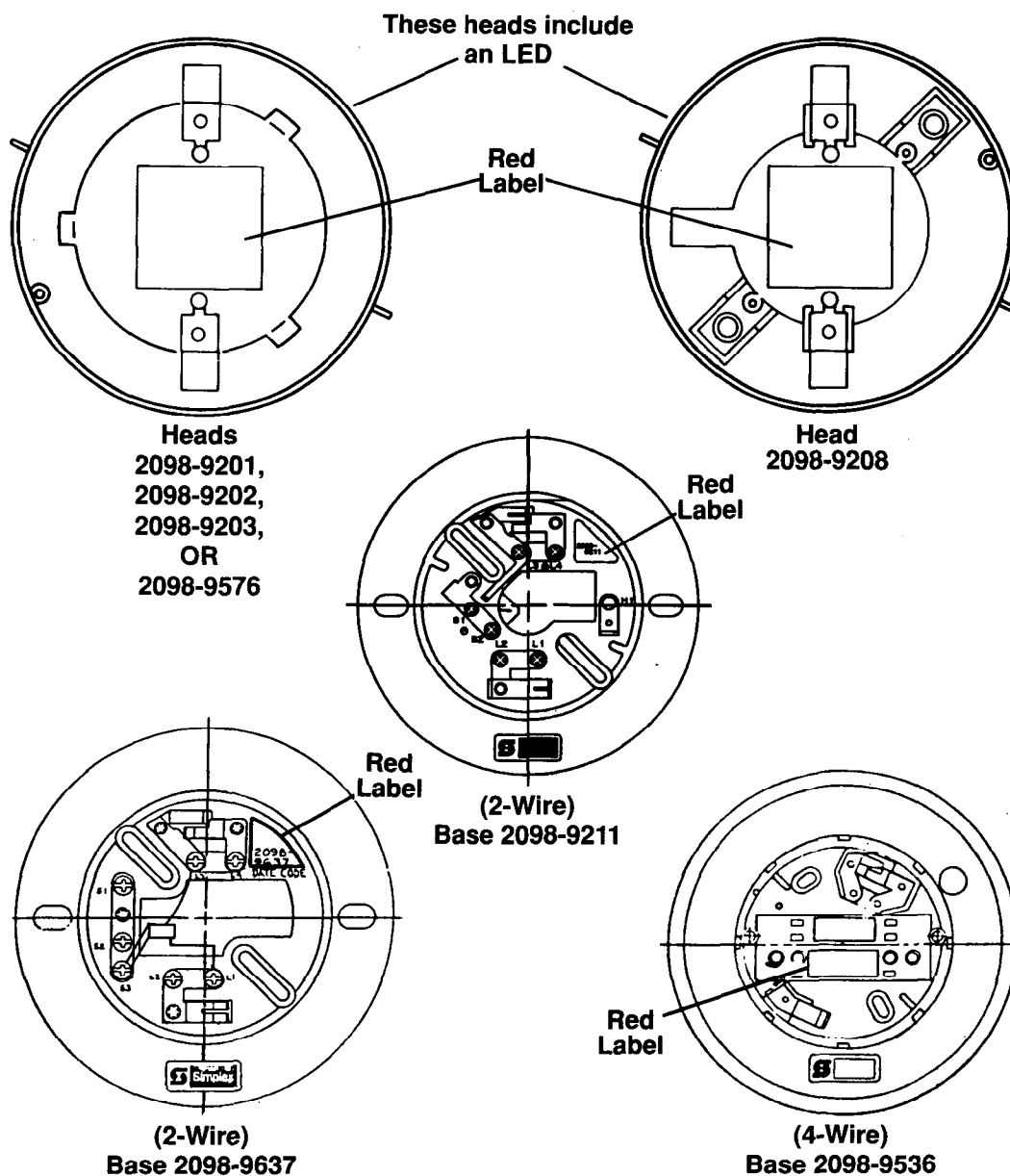

CAUTION

Install the bases in this instruction in accordance with applicable NFPA standards, local codes, and the authorities having jurisdiction. Failure to follow these instructions may result in failure of the detector to initiate an alarm condition. Simplex is not responsible for detectors that have been improperly installed, tested, or maintained.

CAUTION

CONNECT WIRING TO TERMINALS AS SHOWN. DO NOT LOOP WIRE UNDER TERMINALS. BREAK WIRE RUN TO PROVIDE SUPERVISION OF CONNECTIONS.

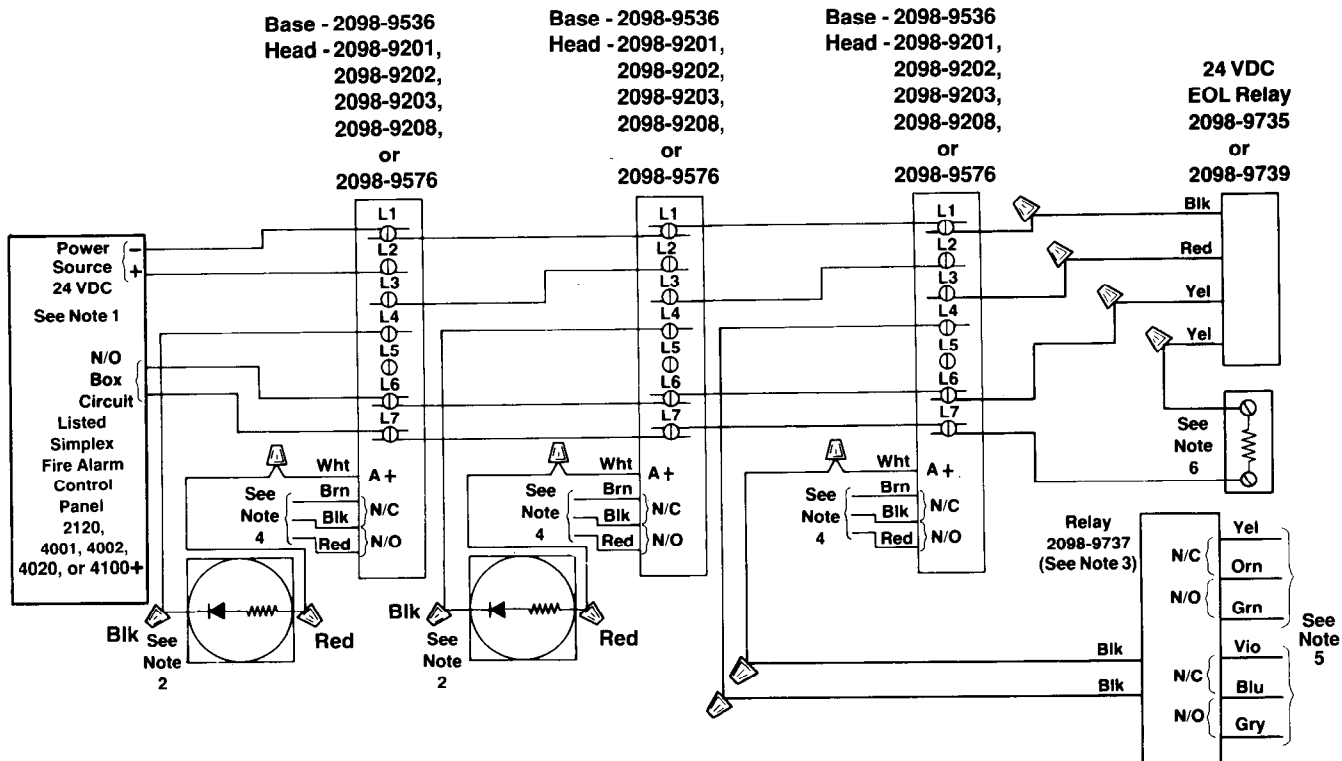

- Notes: 1. Refer to wiring diagrams (841-687) provided with system panel for proper panel connections.
 2. If used, remote LED (2098-9808) is polarized; observe color-coded wiring. DO NOT USE RELAY if LED is used.
 3. DO NOT USE REMOTE LED when relay (2098-9737) is used.
 4. Aux. alarm contacts – form C – each rated 1A @ 24VDC or 115VAC, resistive.
 5. Aux. alarm contacts – two form C – each rated 3A @ 24VDC or 115VAC, resistive.
 6. Refer to wiring diagrams provided with system panel for proper end-of-line resistor value.

2098-9536 BASE CONNECTIONS

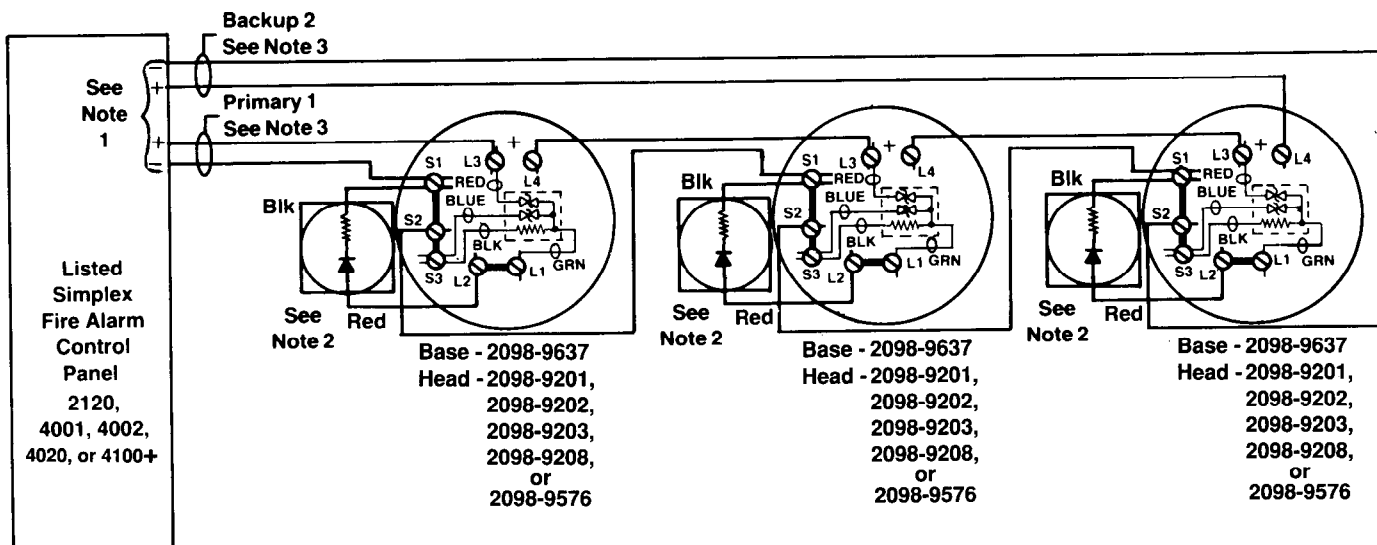

- Notes: 1. Refer to wiring diagrams (841-687) provided with system panel for proper panel connections.
 2. If used, remote LED (2098-9808) is polarized; observe color-coded wiring.
 3. It is recommended that the primary-1 and the backup-2 lines be in separate wire runs and in compliance with local requirements.

2098-9637 BASE CONNECTIONS FOR STYLE D (FORMERLY CLASS A) INITIATE CIRCUIT

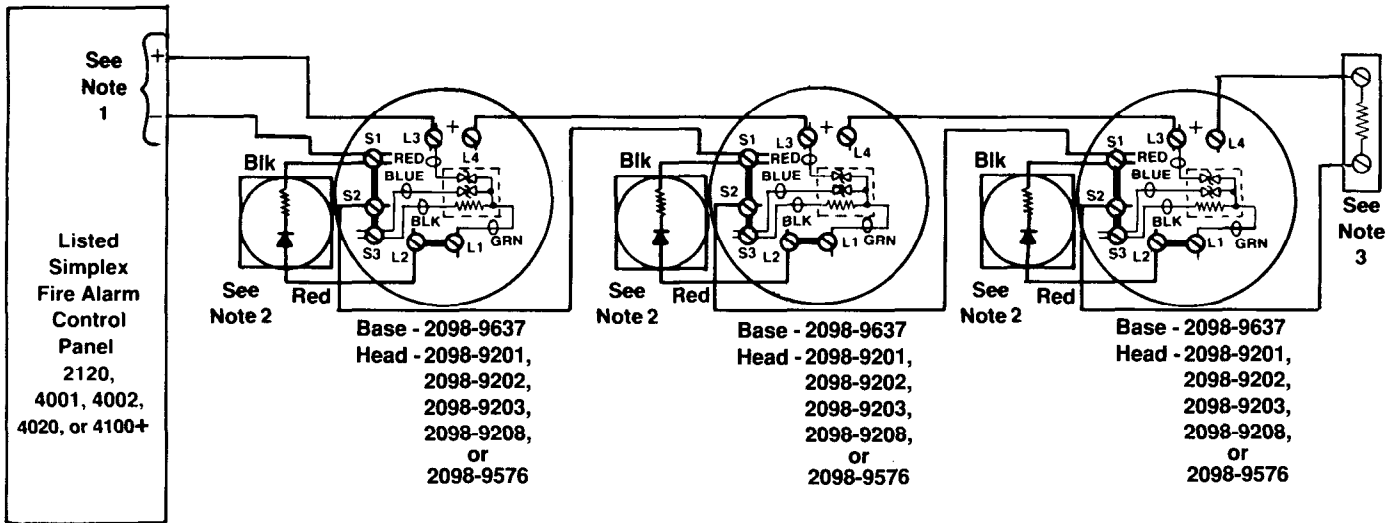

- Notes: 1. Refer to wiring diagrams (841-687) provided with system panel for proper panel connections.
 2. If used, remote LED (2098-9808) is polarized; observe color-coded wiring.
 3. Refer to wiring diagrams provided with system panel for proper end-of-line resistor value.

2098-9637 BASE CONNECTIONS FOR STYLE B (FORMERLY CLASS B) INITIATE CIRCUIT

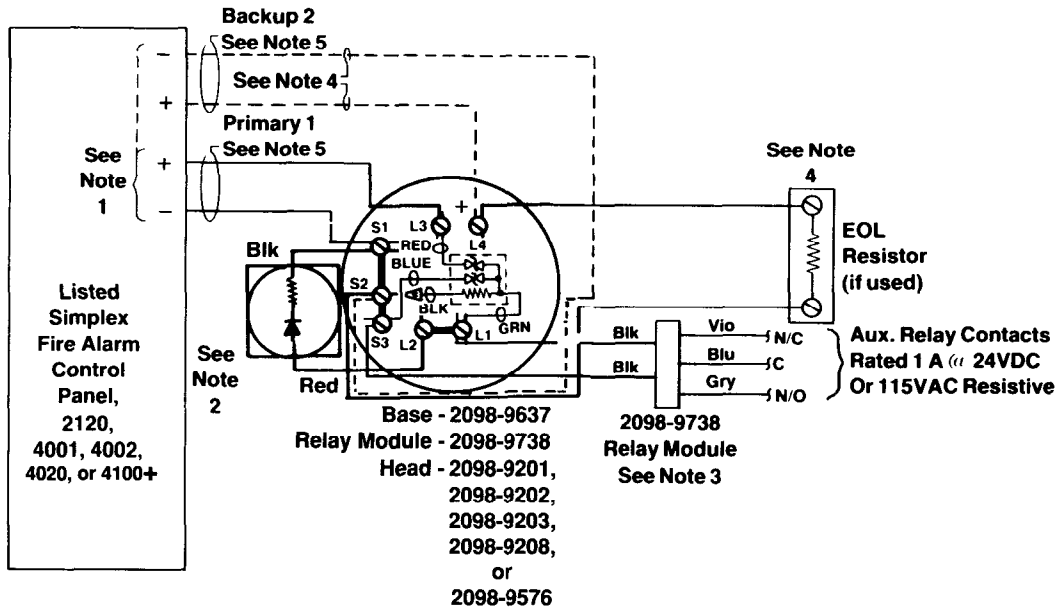

- Notes: 1. Refer to wiring diagrams (841-687) provided with system panel for proper panel connections.
 2. If used, remote LED (2098-9808) is polarized; observe color-coded wiring.
 3. When wiring relay to base, remove resistor (black wire) from base terminal S3. Wire only one base/relay per initiate circuit.
 4. For Style D (formerly Class A) initiate circuit, wire per dotted lines and do not use EOL resistor. If Style B (formerly Class B) initiate circuit, refer to wiring diagrams provided with system panel for proper EOL resistor value.
 5. For Style D (formerly Class A) wiring, it is recommended that the primary-1 and the backup-2 lines be in separate wire runs and in compliance with local requirements.

2098-9637 WITH 2098-9738
 BASE AND RELAY CONNECTIONS FOR STYLE B (FORMERLY CLASS B) OR STYLE D (FORMERLY CLASS A) INITIATE CIRCUIT

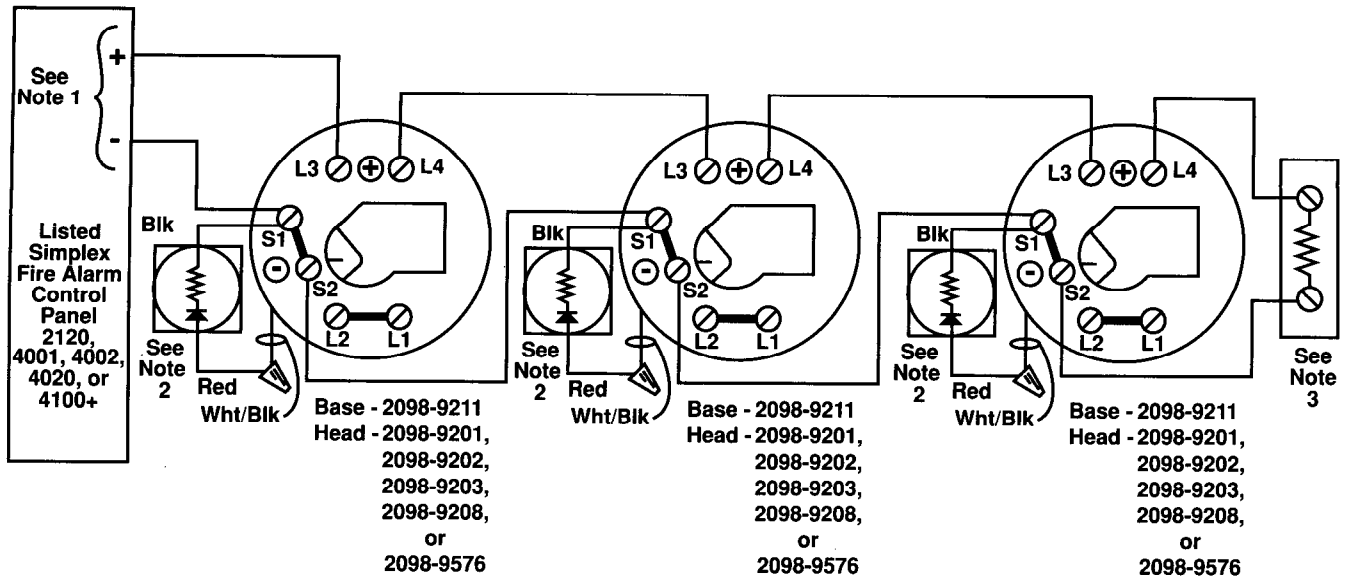

- Notes: 1. Refer to wiring diagrams (841-687) provided with system panel for proper panel connections.
 2. If used, remote LED (2098-9808) is polarized; observe color-coded wiring.
 3. Refer to wiring diagrams provided with system panel for proper end-of-line resistor value.

2098-9211 BASE CONNECTIONS FOR STYLE B (FORMERLY CLASS B) INITIATE CIRCUIT

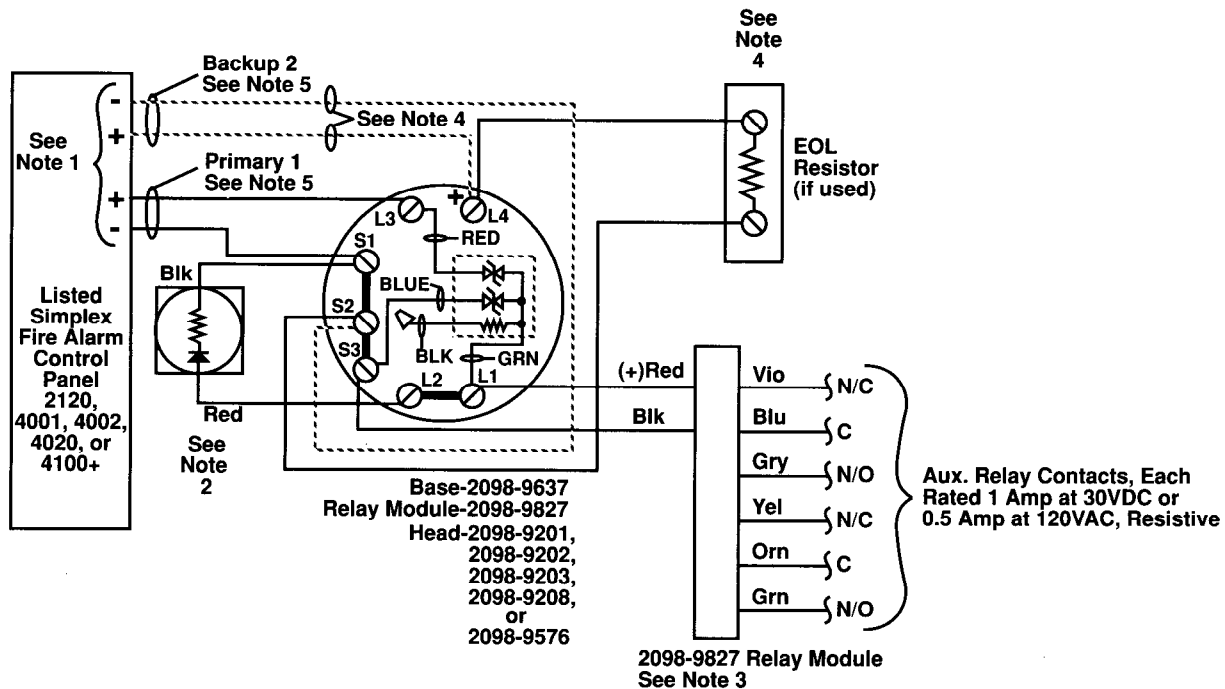

- Notes: 1. Refer to wiring diagrams (841-687) provided with system panel for proper panel connections.
 2. If used, remote LED (2098-9808) is polarized; observe color-coded wiring.
 3. When wiring relay to base, remove resistor (black wire) from base terminal S3. Wire only one base/relay per initiate circuit.
 4. For Style D (formerly Class A) initiate circuit, wire per dotted lines and do not use EOL resistor. If Style B (formerly Class B) initiate circuit, refer to wiring diagrams provided with system panel for proper EOL resistor value.
 5. For Style D (formerly Class A) wiring, it is recommended that the primary-1 and the backup-2 lines be in separate wire runs and in compliance with local requirements.

2098-9637 with 2098-9827

BASE AND RELAY CONNECTIONS FOR STYLE B (FORMERLY CLASS B) OR STYLE D (FORMERLY CLASS A) INITIATE CIRCUIT

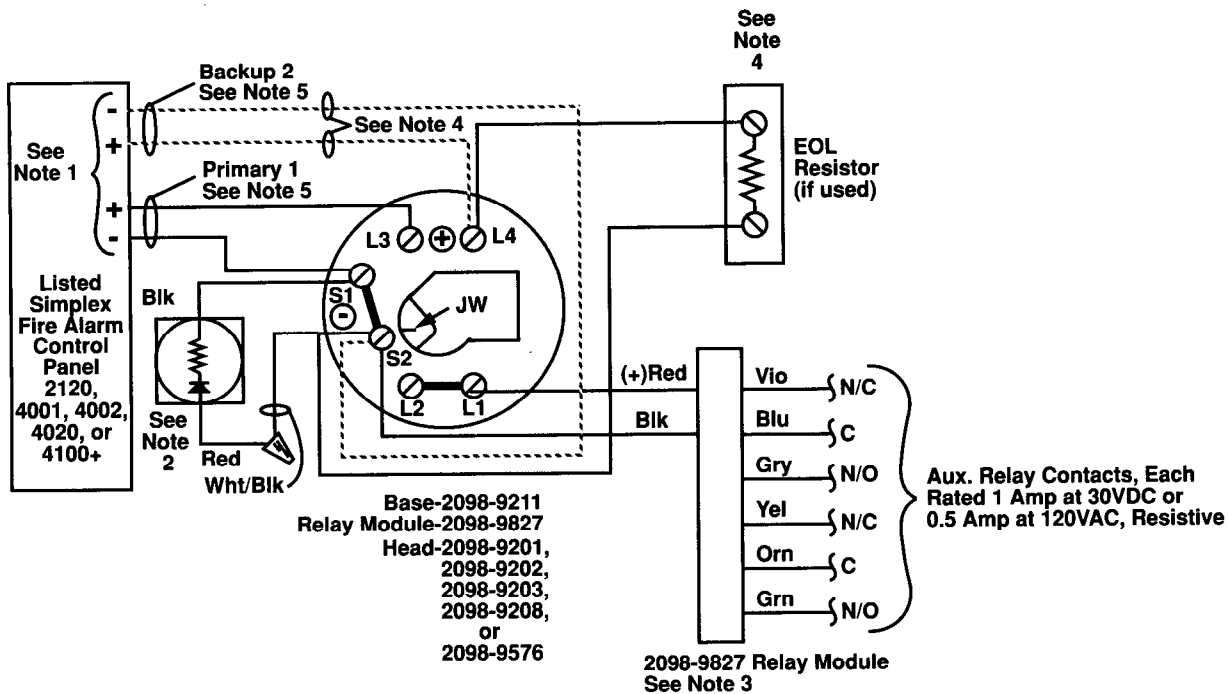

- Notes: 1. Refer to wiring diagrams (841-687) provided with system panel for proper panel connections.
 2. If used, remote LED (2098-9808) is polarized; observe color-coded wiring.
 3. When wiring relay to base, cut JW. Wire only one base/relay per initiate circuit.
 4. For Style D (formerly Class A) initiate circuit, wire per dotted lines and do not use EOL resistor. If Style B (formerly Class B) initiate circuit, refer to wiring diagrams provided with system panel for proper EOL resistor value.
 5. For Style D (formerly Class A) wiring, it is recommended that the primary-1 and the backup-2 lines be in separate wire runs and in compliance with local requirements.

2098-9211 WITH 2098-9827

BASE AND RELAY CONNECTIONS FOR STYLE B (FORMERLY CLASS B) OR STYLE D (FORMERLY CLASS A) INITIATE CIRCUIT

LIMITATIONS OF SMOKE DETECTORS

The smoke detectors used with these bases are designed to activate and initiate emergency action, but will do so only when used in conjunction with other equipment. They are designed for installation in accordance with NFPA standards 72-1990 and 72E.

Smoke detectors will not work without power. AC or DC powered smoke detectors will not work if the power supply is cut off for any reason.

Smoke detectors will not sense fires which start when smoke does not reach the detectors. Smoke from fires in chimneys, in walls, on roofs or on the other side of closed doors may not reach the smoke detector and alarm it.

A detector may not detect a fire developing on another level of a building. For this reason, detectors should be located on every level of a building.

Smoke detectors have sensing limitations, too. Ionization detectors are better at detecting fast, flaming fires than slow, smoldering fires. Photoelectric detectors sense smoldering fires better than flaming fires. Because fires develop in different ways, and are often unpredictable in their growth, neither type of detector is always best, and a given detector may not always provide warning of a fire. In general, detectors cannot be expected to provide warning for fires resulting from inadequate fire protection practices, violent explosions, escaping gases, improper storage of flammable liquids like cleaning solvents, other safety hazards, or arson.

Smoke detectors cannot last forever. Smoke detectors contain electronic parts. Even though detectors are made to last for many years, any of these parts could fail at any time. Therefore, test your smoke detector system per NFPA 72E & 72H at least semi-annually. Clean and take care of your smoke detectors regularly.

