

Features

Releasing control using the Simplex® 4100ES (or 4100U) Fire Alarm Control Panel to provide**:

- Coverage for multiple areas of Automatic Extinguishing Release and/or Deluge and Preaction Sprinkler System Release including audible escalation of events
- Control of compatible Listed/Approved 24 VDC automatic control actuators, one per circuit; or two 12 VDC actuators in series per circuit
- Releasing appliance circuits (RACs) by connecting Notification appliance circuits (NACs) to Suppression Release Peripherals for actuator supervision and control

Audible Escalation of Events:

- Temporal or 20 bpm March Time pattern for first cross-zone alarm
- 120 bpm March Time pattern to indicate releasing timer active
- On steady to indicate releasing timer expired and actuator is activated
- NOTE: Requires NACs dedicated to conventional horn control (not SmartSync™ operation) with strobes controlled on separate NACs

4090-9005/-9006 Suppression Release Peripheral (SRP) with Dual Command Control:

- **Dual** command control requires that **both** IDNet™ communications commands **and** an activated NAC are present to initiate the desired release
- NAC provides wiring supervision to the actuator including monitoring of coil continuity and short circuit supervision to the coil supervision module

Suppression Release Peripheral control features:

- An on-board DC-DC regulator compensates for voltage drops to the peripheral and ensures proper control circuit voltage over a wide operating range
- Provides a single RAC for control of actuators for up to 2 A using a 3 A NAC input (1 A using a 2 A NAC input)

Related system components:

- 4100ES Series control panel with Releasing Appliqué
- Dedicated NAC output from 4100ES (or compatible NAC Extender)
- Coil supervision module, one per RAC
- Maintenance Switch, one per RAC
- Abort Switch connected via an addressable interface module

UL listed to Standard 864

* This product has been approved by the California State Fire Marshal (CSFM) pursuant to Section 13144.1 of the California Health and Safety Code. See CSFM Listings 7165-0026:251 and 7300-0026:313 (SRP) for allowable values and/or conditions concerning material presented in this document. It is subject to re-examination, revision, and possible cancellation. Additional listings may be applicable; contact your local Simplex product supplier for the latest status. Listings and approvals under Simplex Time Recorder Co. are the property of Tyco Safety Products Westminster.

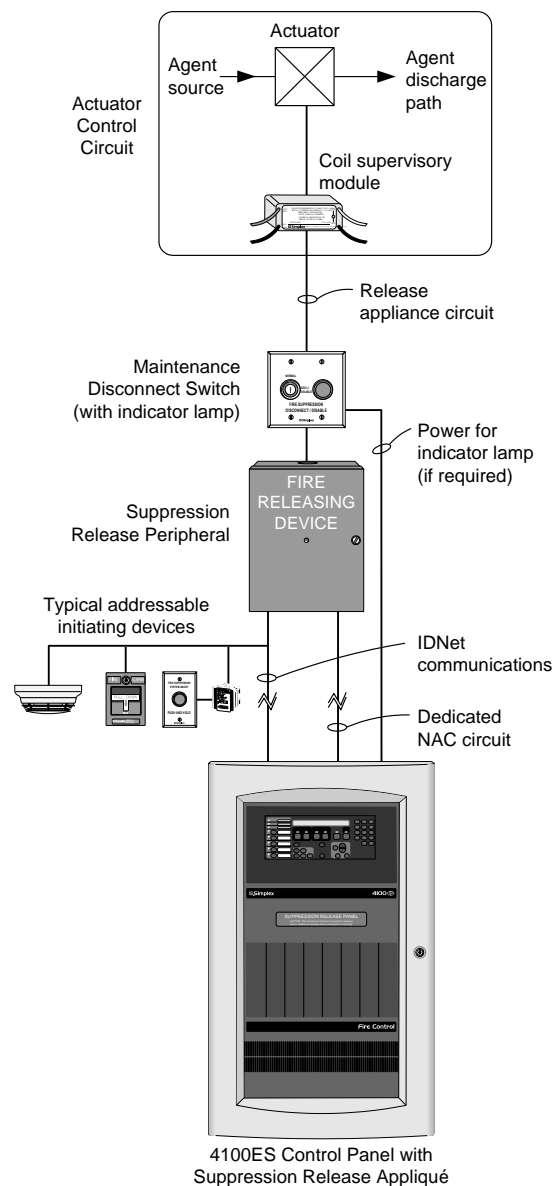

4100ES Series Releasing Control Typical Block Diagram

Introduction

When combined with Suppression Release Peripherals, the 4100ES series fire alarm control panel provides actuator supervision and control for use in automatic extinguishing, and deluge or preaction releasing systems. Hazard area initiating and notification devices are controlled using either conventional or addressable circuits per standard 4100ES capabilities. The necessary releasing system logic is implemented within the 4100ES control panel as required for the local application.

** Release Control operation described in this document is also available with 4100U Control Panels with software revision 11.05 or higher. Refer to data sheet S4100-0031 for model 4100ES control panel details including IDNet communications information.

Automatic Extinguishing Release Systems

These systems automatically activate electrically controlled actuators for the release of a fire extinguishing agent (such as dry chemical, water spray, foam, CO₂, or clean agent) in response to fire detection device inputs as determined by programming of the host fire alarm control panel.

Automatic Extinguishing Release System Panels are required to have a minimum of 24 hours of standby power. Initiating devices must be Listed/Approved for the application, and may be wired either Class A or B. Control actuators must be electrically compatible with the control panel circuits and power supplies, and are wired Class B to provide coil supervision.

Deluge or Preaction Sprinkler Systems

These systems automatically activate water control actuators in response to fire detection device inputs.

Deluge Sprinkler Systems employ open sprinkler heads and provide water flow when the fire detection system activates a common automatic water control actuator. They are used to deliver water simultaneously through all of the system sprinkler heads. This type of system is applicable where the immediate application of large quantities of water over large areas is the proper fire response.

Preaction Sprinkler Systems are similar to deluge systems except that normally closed sprinkler heads are used and supervisory air pressure is maintained in the pipe. Operation requires both an activated sprinkler head and an activated fire alarm initiating device with specific programming determined at the host fire alarm control panel.

Releasing System Requirements

1. **Releasing actuators** are controlled from a Suppression Release Peripheral (4090-9005 or 4090-9006). Connections are 2-wire, Class B releasing circuits **with only one 24 VDC actuator per circuit**. Where applicable, two, 12 VDC actuators in series, or one 12 VDC actuator with manufacturer supplied resistor may be used.
2. **Coil Supervision Module 2081-9046** must be wired electrically before the actuator and located in the actuator wiring junction box. (Refer to diagram on page 5.) The connected RAC provides continuity supervision of the actuator coil and wiring and provides short circuit supervision to the coil supervision module.
3. **Cross-zoning or other alarm initiation logic** per system requirements, is to be implemented by programming at the fire alarm control panel.
4. **UL Listed Automatic Extinguishing Releasing operation** requires that: battery standby must be a minimum of 24 hours with 5 minutes of alarm and that listed actuators are used, refer to list on page 6.

Releasing System Requirements (Continued)

5. **FM Approved Automatic Extinguishing Release** requires secondary standby to be a minimum of 24 hours with 5 minutes of alarm. Actuators must be electrically compatible.
6. **FM Approved Deluge and Preaction Sprinkler operation** requires that: initiating device circuits be Class A and wired to Listed/Approved devices; standby power capacity must be a minimum of 90 hours with 10 minutes of alarm; and that compatible Automatic Water Control Valves must be used. (Refer to actuator list on page 7.)
7. **Maintenance Switches**, one per RAC, are required per NFPA 72[®], the *National Fire Alarm Code*[®] (2002 Edition, Chapter 6) to allow the system to be tested or serviced without actuating the fire suppression systems. *Their use may not be allowed in some jurisdictions, always confirm local requirements.* When used, Simplex Maintenance Switches are required to ensure that operation initiates a supervisory condition.
8. **Abort Switches** are available when abort operation is required. When used, connect to an addressable Supervised IAM model 4090-9001 or similar addressable adapter module. The Simplex abort switch and the IAM mount in a single gang box, 2-1/2" minimum depth.
9. **Addressable Manual Releasing Stations** are used to initiate activation of the releasing actuators with the appropriate time delay implemented by the fire alarm control panel.
10. **Notification Requirements.** Each hazard area typically requires general audible and visible fire alarm notification and additional dedicated NACs for area releasing status notification. Suppression releasing is compatible with conventional panel mounted NAC modules as well as for use with the 4009 IDNet NAC Extender.
11. **Additional Suppression Release Peripheral Reference.** Refer to Installation Instructions 579-385.

Additional Releasing Systems Reference

For additional information, refer to Factory Mutual Research Corporation (FMRC) "FMRC Approval Guide," FM Approval standard "Deluge Systems and Preaction Systems."

Please note that proper operation of releasing control systems requires that the system design, installation, and maintenance be performed correctly and in accordance with all applicable local and national codes, and equipment manufacturer's instructions. No liability for total system operation is assumed or implied.

Product Selection

4100ES Releasing Control System Modules

Model	Description	Reference
2081-9046	Coil Supervision Module	Required , one per RAC, mounts in the releasing actuator wiring junction box; see specifications section for details
2080-Series*	Maintenance Switches	One per RAC; flush or surface mount; indicator lamp models require separate 24 VDC wiring
2080-9056*	Flush mount	As required, connects via an IDNet addressable interface module; mounted on a single gang stainless steel plate; installation requires a single gang box, 2-1/2" (64 mm) minimum depth
2080-9057*	Surface mount	
	Abort Switch	

* Refer to data sheet S2080-0010 for Abort and Maintenance switch details.

Releasing Appliqués, Required for 4100ES Suppression Releasing Applications

Model	Description	Reference
4010-9830	English	Suppression Releasing Appliqué; field applied (same appliqué as is used on the Simplex model 4010 Suppression Release Panel)
4010-9830CAF	French	

Suppression Release Peripheral and Accessories

Model	Description	Reference
4090-9005	Basic Suppression Release Peripheral on mounting plate	Requires mounting box 2975-9227, ordered separately
4090-9006	Suppression Release Peripheral mounted in red box; required for ULC listing	Includes LED indicator on front of door
2975-9227	Red mounting box; required for 4090-9005	These items are included with model 4090-9006
4090-9812	Red LED IDNet communications indicator option kit; mounts on door of 2975-9227 box	

Additional Product Data Sheet Reference

Subject	Data Sheet	Subject	Data Sheet
Releasing System Abort and Maintenance Switches	S2080-0010	4100 Series, Panel Mount 24 Point I/O and Annunciator Modules	S4100-0032
Addressable Manual Stations for Releasing Applications	S4099-0002	4100 Series, Remote Mount 24 Point I/O and Annunciator Modules	S4100-0005
Addressable Manual Stations for Standard Applications	S4099-0001	TrueAlarm® Sensors and Bases	S4098-0019
4100ES Basic Control Panels	S4100-0031	TrueAlert® Electronic Horns	S4901-0010
Supervised IAM	S4090-0001	TrueAlert Non-Addressable Strobes (V/O)	S4906-0001
Addressable Zone Adapter Modules	S4090-0003	TrueAlert Non-Addressable 4-Wire Horn/Strobes (A/V)	S4903-0011

Contact your local Simplex product supplier for additional information on compatible IDNet addressable devices and TrueAlert notification appliances.

4100ES Releasing System One-Line Connection Reference

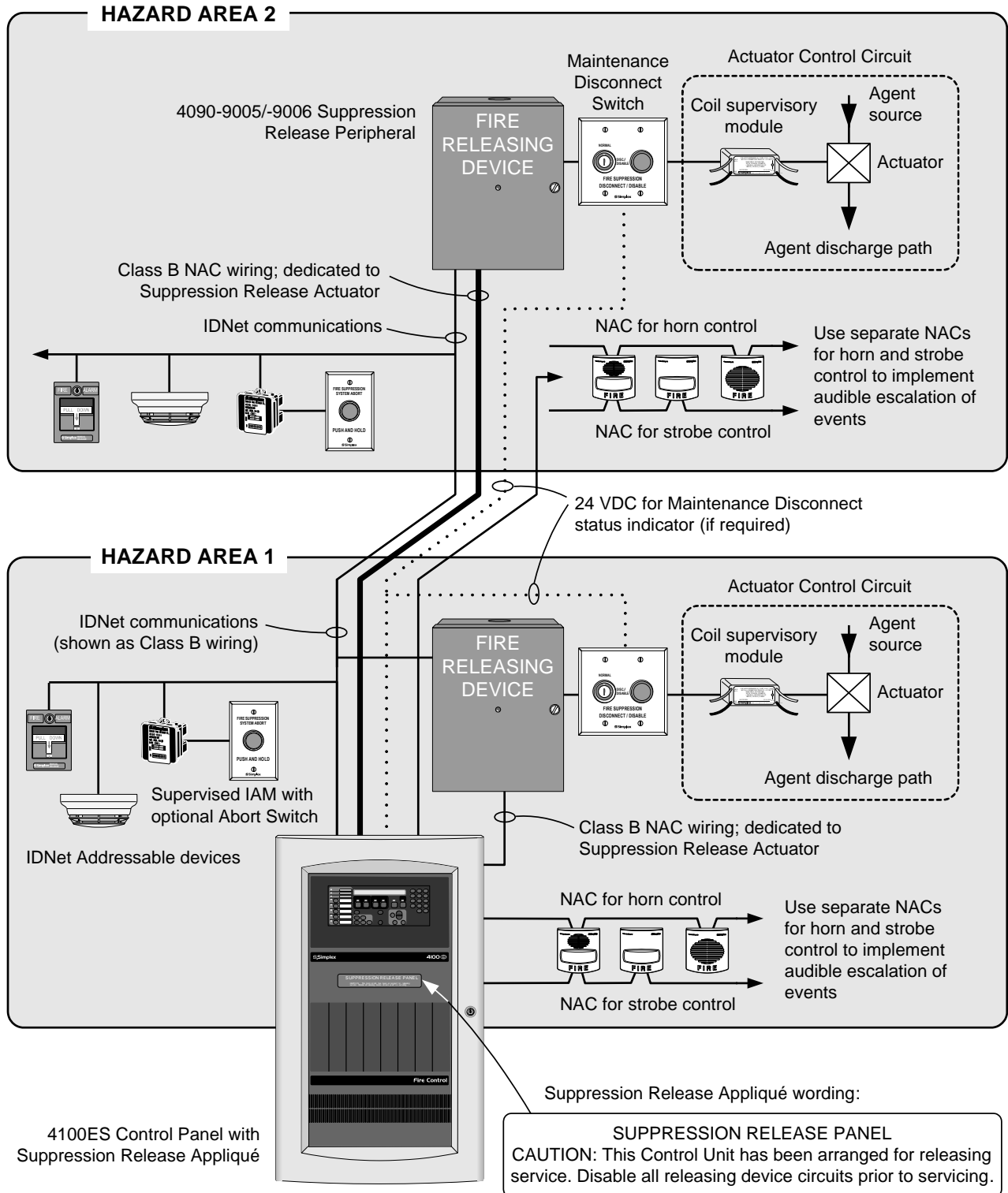

Suppression Release Peripheral Wiring Reference

Maximum Release Appliance Circuit (RAC) Wiring Distances from Suppression Release Peripheral to the Valve Solenoid (based on a total drop of 0.6 V)

RAC Output Current (refer to solenoid rating)	Distance						Total Line Resistance
	18 AWG		16 AWG		14 AWG		
0.50 A	74 ft	23 m	118 ft	36 m	188 ft	57 m	1.06 Ω
0.75 A	50 ft	15 m	79 ft	24 m	126 ft	38 m	0.71 Ω
1.00 A	37 ft	11 m	59 ft	18 m	94 ft	29 m	0.53 Ω
1.25 A	30 ft	9 m	47 ft	14 m	75 ft	23 m	1.06 Ω
1.5 A	25 ft	7.6 m	39 ft	12 m	63 ft	19 m	0.71 Ω
1.75 A	21 ft	6.4 m	34 ft	10 m	54 ft	16 m	0.53 Ω
2.00 A	19 ft	5.8 m	30 ft	9 m	47 ft	14 m	0.53 Ω

Metric wire equivalents: 18 AWG = 0.82 mm²; 16 AWG = 1.31 mm²; 14 AWG = 2.08 mm²

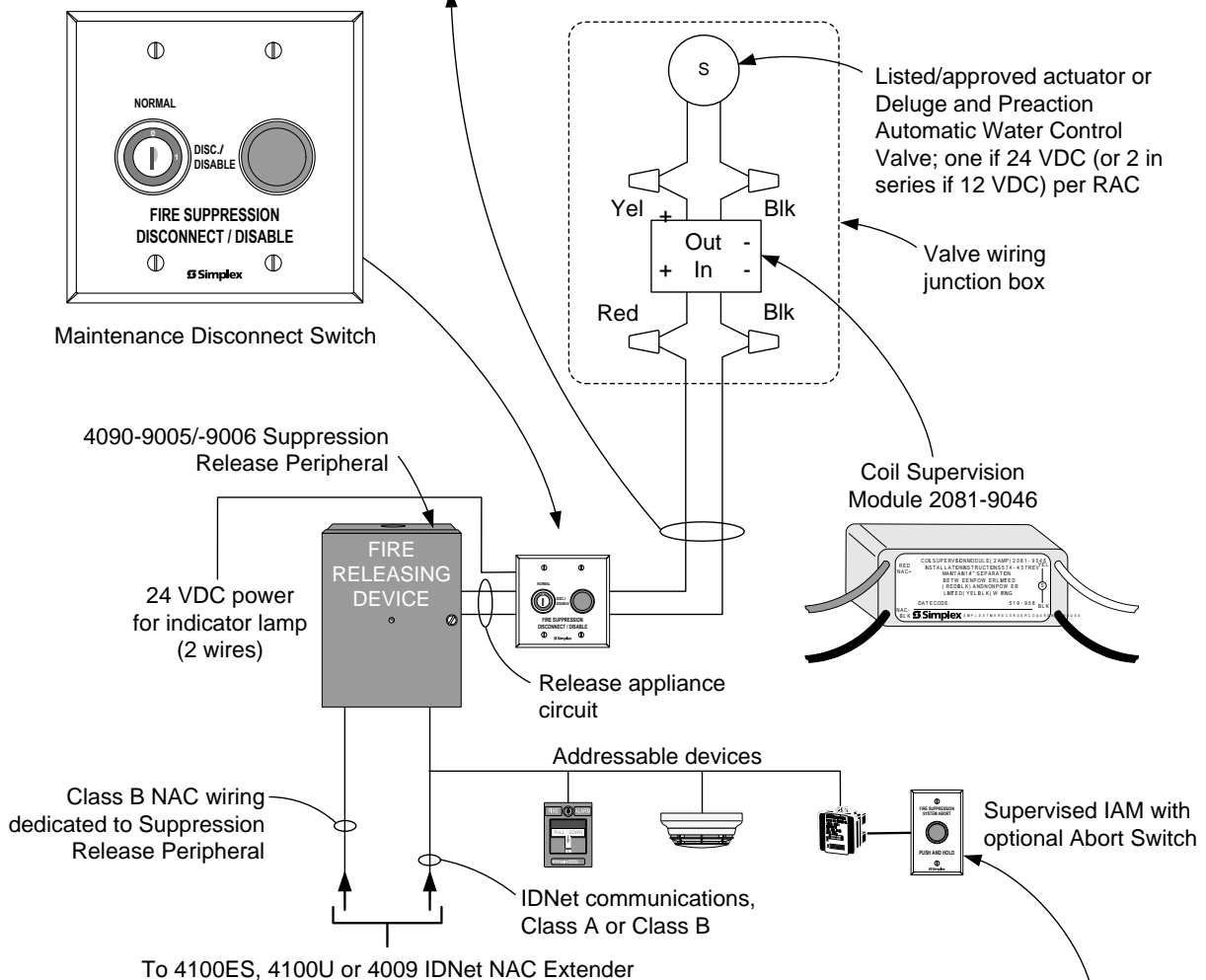

Maximum Notification Appliance Circuit (NAC) Wiring Distances to a Suppression Release Peripheral (0.5 A to 1.75 A drop is based on a total drop of 3.4V; 2 A drop is based upon a total drop of 1.2 V)

RAC Output Current (refer to solenoid rating)	Distance						Total Line Resistance
	18 AWG		16 AWG		14 AWG		
0.50 A	250 ft	76 m	399 ft	122 m	635 ft	194 m	3.58 Ω
0.75 A	167 ft	51 m	266 ft	81 m	423 ft	129 m	2.39 Ω
1.00 A	125 ft	38 m	199 ft	61 m	317 ft	97 m	1.79 Ω
1.25 A	100 ft	30 m	159 ft	48 m	254 ft	77 m	1.43 Ω
1.5 A	84 ft	26 m	133 ft	41 m	212 ft	65 m	1.19 Ω
1.75 A	72 ft	22 m	114 ft	35 m	181 ft	55 m	1.02 Ω
2.00 A	25 ft	7.6 m	39 ft	12 m	63 ft	19 m	0.36 Ω

Metric wire equivalents: 18 AWG = 0.82 mm²; 16 AWG = 1.31 mm²; 14 AWG = 2.08 mm²

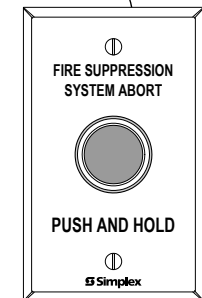

2080-9056/-9057 Abort Switch (as required)

Specifications

Suppression Release Peripheral 4090-9005 and 4090-9006

Communications	IDNet, one address				
RAC Output Rating	with 4100ES/4100U	2 A maximum	At nominal 24 VDC, regulated; refer to NAC Power Requirements for more detail		
	with 4009 IDNet NAC Extender	1 A maximum			
NAC Power Requirements	Voltage	16 to 32 VDC (nominal 24 VDC)			
	Supervisory Current	No additional current required, circuit appears as standard end-of-line (EOL) NAC loading			
	Alarm Current Reference (RAC current = actuator current)	RAC Current	NAC Current	RAC Current	NAC Current
		0.5 A	0.845 A	1.25 A	2.14 A
		0.75 A	1.28 A	1.5 A	2.56 A
0.87 A		1.5 A	1.75	3 A	
1 A	1.71 A	2 A			
Wire Connections	Screw terminals for input and output wiring, 18 to 12 AWG wire (0.82 mm ² to 3.31 mm ²)				
IDNet Wiring Distance Reference	Up to 2500 ft (762 m) from the IDNet source module				
	Up to 10,000 ft (3048 m) total Class B wiring distance including T-Taps				
	Compatible with Simplex 2081-9044 Overvoltage Protectors				
Dimensions	See installation reference on page 8				
Operating Temperature	32° to 120° F (0° to 49° C) indoor operation only				
Operating Humidity Range	10 to 90% RH at 90° F (32° C)				

Coil Supervision Module 2081-9046

Construction	Epoxy encapsulated
Dimensions	1-3/8" W x 2-7/16" L x 1-1/16" H (34 mm x 62 mm x 27 mm)
Wiring	18 AWG (0.82 mm ²) wire leads, color coded
Current Rating	2 A Maximum; internally fused at 3 A, non-replaceable

Compatible UL Listed Valves and Actuators

MFG.	Model Number	Coil Details	MFG.	Model Number	
ANSUL	*AUTOMAN II-C Assembly; solenoid 17728; coil 25924	12 VDC, 458 mA	ASCO	8210A107 (097617-005D coil) 1/2" NPS, 5/8" orifice, 24 VDC	
	AUTOMAN II-C Explosion-Proof Releasing Device; solenoid 31492; coil 31438	24 VDC, 467 mA		8210G207 (238310 coil) 1/2" NPS, 1/2" orifice	
	*AUTOMAN II-C Assembly; solenoid 68739; coil 25924,	12 VDC, 458 mA		8211A107 (097617-005D coil) 24VDC	
	Solenoid Electric Actuator; solenoid 73111; coil 73097	24 VDC, 1 A		HV2628571 (23810 coil) N.C. 1/2" NPS, 1/2" orifice	
	*CV90 HF Electric Actuator 73327; may use 73606 in-line resistor for 12 VDC	9 VDC max, 450 mA		HV2648581 (23810 coil) N.O. 1/2" NPS, 1/2" orifice	
	LP CO2 w/ASCO solenoid 422934,	24 VDC, 442 mA		R8210A107 (097617-005D coil) 1/2" NPS, 5/8" orifice	
	LP CO2 double action solenoid 430948	24 VDC, 438 mA		T8210A107 (097617-005D coil) 1/2" NPS, 5/8" orifice	
	LP CO2 3-way selector valve solenoid 433419	24 VDC, 438 mA		Pyro-Chem	ECH Electrical Control Head (551201)
	Electric Actuator 24 VDC solenoid 570537	24 VDC, 250 mA			Explosion-Proof Electric Actuator (570147)
Skinner	Removable Electric Actuator (570209) 0.2 A				
	71395SN2ENJ1NOH111C2 (Skinner coil H111C2) 1/4", NPS, 1/16"				
	73212BN4TN00NOC111C2 (Skinner coil C111C2) 1/2", 5-300 psi				
	73212BN4TNLVNOC322C2 (Skinner coil C322C2) 1/2", NPS, 0.92 A, 250 psi				
	73218BN4UNLVNOH111C2 (Skinner coil H111C2)				
73218BN4UNLVNOC111C2 (Skinner coil C111C2) 1/2", NPS, 5/8 in. orifice					

* 12 VDC coils, either wire two in series for 24 VDC activation, or, if available from manufacturer, use series resistor

FM Approved Water Control Valves

FM Group	Manufacturer	Model Number	Details
A	Skinner	LV2LBX25*	24 VDC, 11 W, 458 mA, 1/2 inch NPS, 1/2 inch orifice
B	ASCO	T8210A107	24 VDC, 16.8 W, 700 mA, 1/2 inch NPS, 5/8 inch orifice
		R8210A107	
		8210A107	
D	ASCO	8210G207	24 VDC, 10.6 W, 440 mA, 1/2 inch NPS, 1/2 inch orifice
E	Skinner	73218BN4UNLVNOC111C2*	24 VDC, 10 W, 420 mA, 1/2 inch NPS, 5/8 inch orifice
		73212BN4TN00N0C111C2	24 VDC, 10 W, 420 mA, 1/2 inch NPS, 5/8 inch orifice; 5-300 psi rated working pressure
F	Skinner	73212BN4TNLVNOC322C2	24 VDC, 22 W, 1/2 inch NPS, 920 mA, 250 psi (1725 kPa), 1/2 inch orifice
G	Skinner	71395SN2ENJ1NOH111C2	24 VDC, 10 W, 420 mA, 1/4 inch NPS, 1/16 inch orifice, 250 psi (1725 kPa) rated working pressure
I	Vitaulic	Series 753-E solenoid valve	24 VDC, 8.7 W, 1/2 inch NPS, 364 mA, 300 psi (2069 kPa), 1/2 inch orifice
J	Viking	11591 and 11592	Explosion proof solenoid valves, 24 VDC, 10 W, 1/2 inch NPS, 300 psi (2069 kPa), 4.1 Cv
		11595 and 11596	
K	Viking	11601 and 11602	NC solenoid valve, 24 VDC, 9 W, 1/2 inch NPS, 250 psi (1725 kPa), 6.2 Cv

* For new applications, LV2LBX25 has been replaced by model number 73218BN4UNLVNOC111C2.

Suppression Release Peripheral Installation Reference Diagram

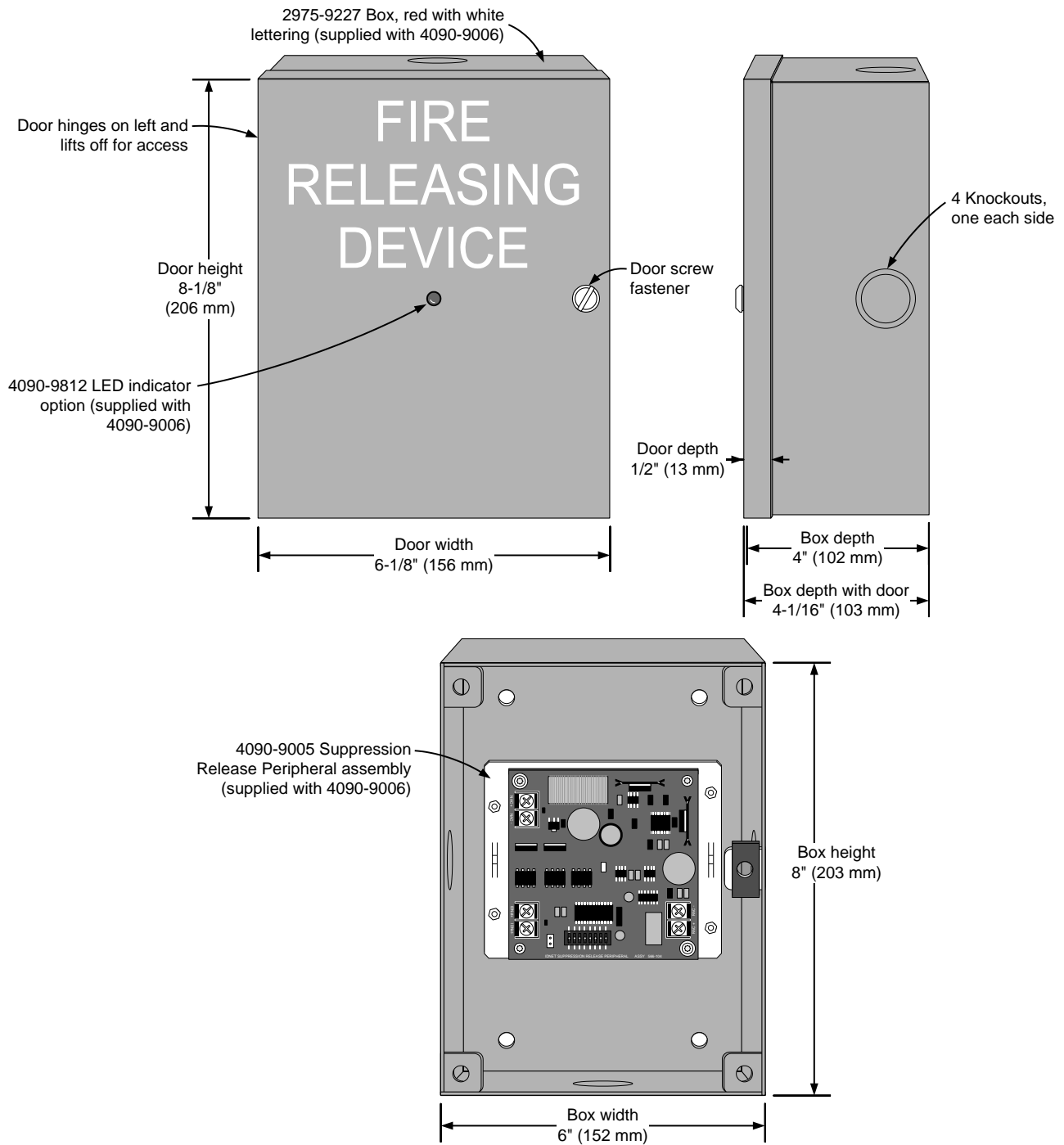

Tyco is a registered trademark of Tyco International Services GmbH and is used under license. Simplex, the Simplex logo, TrueAlarm, TrueAlert, SmartSync, and IDNet are trademarks of Tyco International Ltd. and its affiliates and are used under license.



Tyco Safety Products Westminister • Westminister, MA • 01441-0001 • USA

S4100-0040-5

www.tycosafetyproducts-usa-wm.com

© 2011 Tyco Safety Products Westminister. All rights reserved. All specifications and other information shown were current as of document revision date and are subject to change without notice.