

Features

Network Display Unit provides annunciation for up to 12,000 network points:

- The basic NDU is a special purpose master controller that includes a network interface module
- Combining a basic NDU with a Voice Command Center (VCC) provides an additional separate Network node within the same cabinet for control of Network level Emergency Voice/Alarm Communications Equipment

Master Controller (top) bay:

- Master controller assembly with operator interface
- Enhanced CPU with dual configuration programs, convenient service port access, and capacity for up to 12,000 points
- System power supply (SPS) and charger (9 A total) with on-board programmable auxiliary output
- Operator interface that is conveniently color coded with raised switches providing high confidence feedback
- Available with InfoAlarm Command Center expanded content user interface (refer to data sheet S4100-0045)
- Construction that is optimized for easy installation, upgrade, and maintenance
- Glass door (ordered separately) provides view of available operator controls visible behind locked door

Standard addressable interfaces include:

- Remote annunciator module support via RUI (remote unit interface) communications port

NDU field installed option modules include:

- DACT and City Connection
- Service modems for remote panel status inquiry
- RS-232 ports for printers or maintenance terminals
- Alarm relays and expansion power supplies
- SafeLINC Internet Interface

For NDU with VCC:

- Optional features are similar to a networked fire alarm control panel and an extensive list of modules are available for; initiating, notification, and user interface

Listed to:

- UL Std. 864, Fire Detection and Control (UOJZ), and Smoke Control Service (UUKL)
- UL Std. 2017, Process Management Equipment (QVAX)
- UL Std. 1076, Proprietary Alarm Units-Burglar (APOU)
- UL Std. 1730, Smoke Detector Monitor (UULH)
- ULC Std. S527-99

* See pages 4-6 for models that are UL or ULC listed and for additional product listing details. This product has been approved by the California State Fire Marshal (CSFM) pursuant to Section 13144.1 of the California Health and Safety Code. See CSFM Listing 7165-0026:251 for allowable values and/or conditions concerning material presented in this document. Accepted for use – City of New York Department of Buildings – MEA35-93E. Additional listings may be applicable; contact your local Simplex product supplier for the latest status. Listings and approvals under Simplex Time Recorder Co. are the property of Tyco Fire Protection Products.

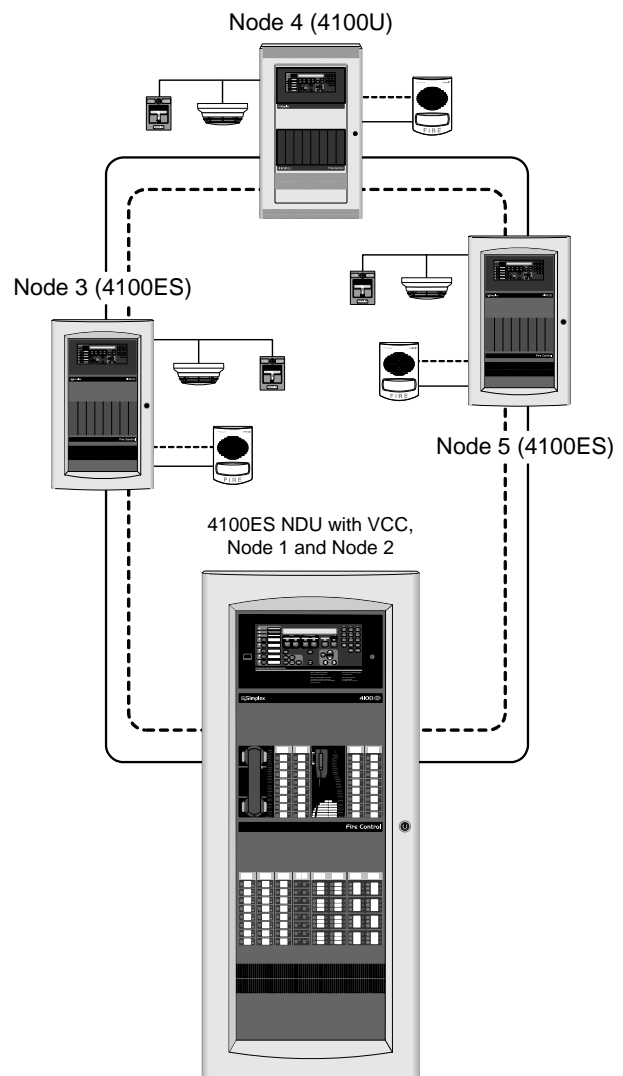

Network One-Line Diagram Showing an NDU with VCC

Introduction

The 4100ES Network Display Unit is a network level annunciator and manual system/point controller. It provides alphanumeric annunciation for up to 12,000 Network points and/or point lists and can be programmed to function as the network master controller for Alarm Silence, Trouble Acknowledge, and System Reset.

4100U Series Products Note. The system modules and features listed in this data sheet are both compatible with, and listed for use with 4100U series fire alarm control panels. Contact your local Simplex® product supplier for details.

Introduction (Continued)

Network Overview. When connected to other Network nodes, individual fire alarm control panels become components of a distributed intelligence system. Each panel that directly connects to the network is called a network “node” and is capable of performing individual supervision and control on its locally connected devices but has the ability to inform the 4100ES NDU (as well as other network control panels) of point status and panel condition. This allows system information to reach the proper location for appropriate system response.

Multiple 4100ES NDUs (separately packaged) can be connected to a Network to duplicate common information at separate locations, or direct selected information by type such as troubles, alarms, control, etc.

NDU Module Bay Description

The NDU Master Controller Bay (top) includes a special purpose system power supply with battery charger (SPS), the master controller board, a Network Interface Module, and operator interface equipment similar to that used on the standard fire alarm control modules. Slots 1 and 2 are available for single slot panel mounted modules.

The NDU with VCC includes an expansion bay with *separate*: master controller board, Network Interface Module, and a standard SPS. This results in two separate Network nodes residing within the same cabinet.

In this bay (typically the second expansion bay), Slots 1 and 2 are available for single slot panel mounted modules and optional LED/switch modules can also be mounted.

The Battery Compartment (bottom) accepts two batteries, up to 50 Ah, to be mounted within the cabinet without interfering with module space.

Refer to the NDU with VCC internal module bay reference illustration for typical three bay cabinet module location.

Operator Interface Detail Reference

The following illustration identifies the primary functions of the operator interface.

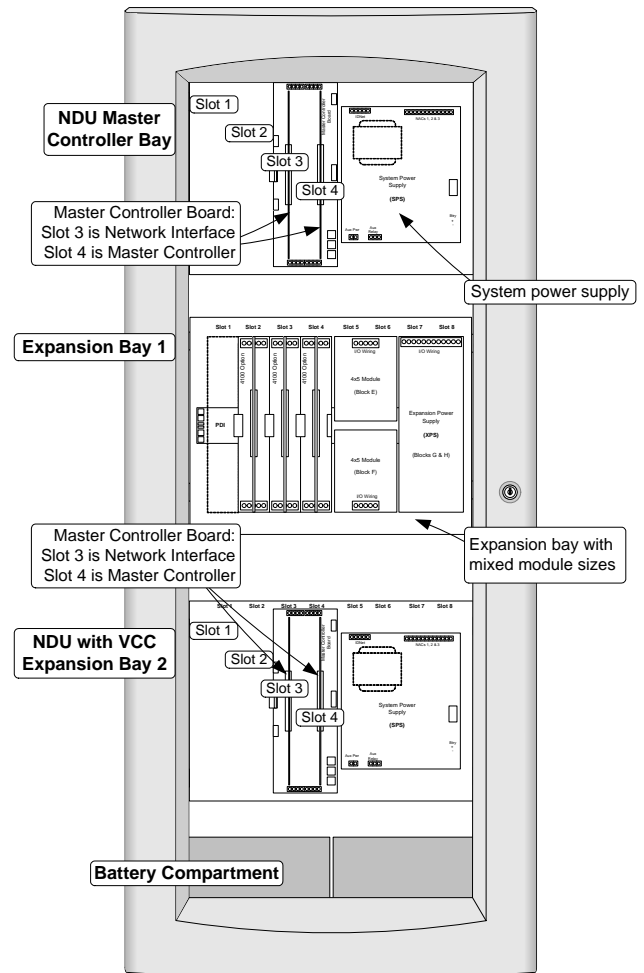
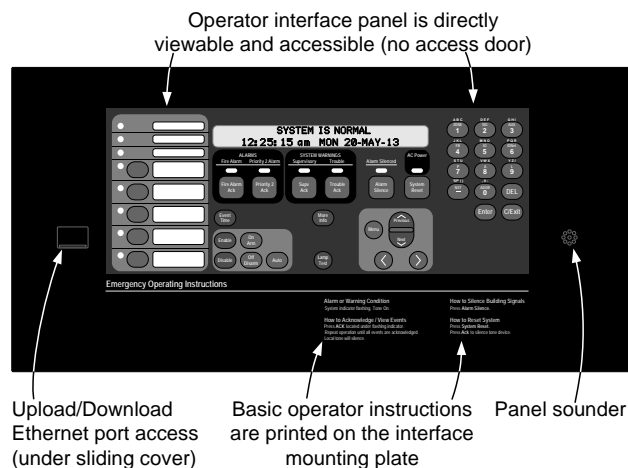

NDU with VCC Internal Module Bay Reference (exact layout is determined by specific system requirements)

Packaging Availability

- Modules are power-limited (unless specifically noted otherwise)
- Enclosure are available for one, two, or three bay sizes or for cabinet rack mounting
- Additional cabinets can be mounted close-nipped for module expansion
- Boxes, doors with tempered glass inserts, and dress panels are available in beige or red (ordered separately)
- Refer to data sheet S4100-0037 for enclosure details

Software Feature Summary

- Selectable service override allows authorized operators to clear alarm conditions during System Reset even if status has gone to trouble before reset occurred
- Duplicate address error detection
- Convenient PC programming using a Microsoft Windows user interface based program

Operator Interface

Convenient Status Information. With the locking door closed, the glass window allows viewing of the display, status LEDs, and available operator switches. Features include a two-line by 40-character, wide viewing angle (super-twist) LCD with status LEDs and switches as shown in the illustration below.

LED indicators describe the general category of activity being displayed with the LCD providing more detail. For the authorized user, unlocking the door provides access to the control switches and allows further inquiry by scrolling the display for additional detail.

Operator Interface Features

- Convenient and extensive operator information is provided using a logical, menu-driven display
- Multiple automatic and manual diagnostics for maintenance reduction
- Alarm and Trouble History Logs (up to 1250 entries for each, 2500 total events) are available for viewing from the LCD, or capable of being printed to a connected printer, or downloaded to a service computer
- Convenient PC programmer label editing
- Password access control

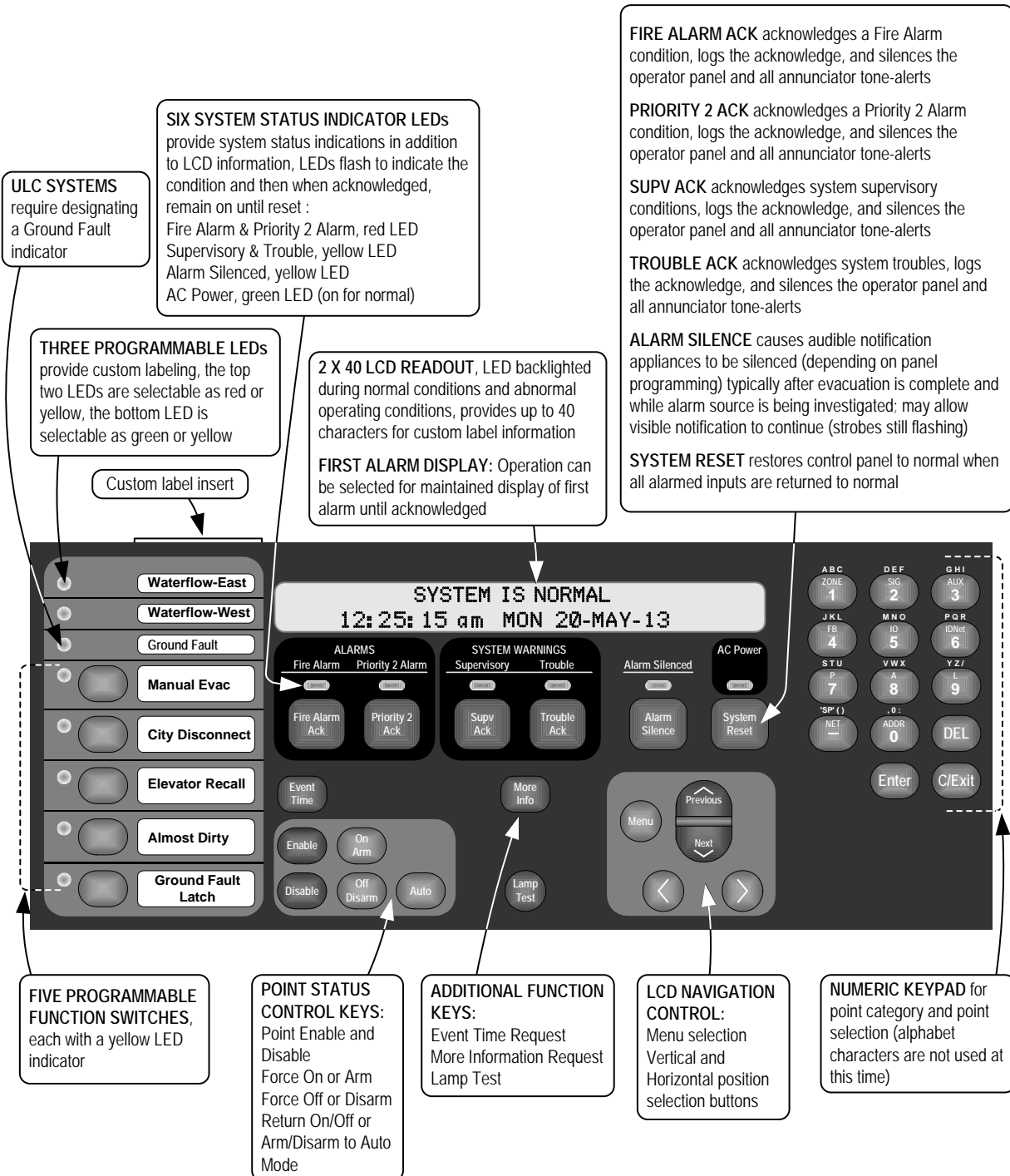

Standard Module Details

Master Controller & Motherboard:

- Mounts in Slot 4 of a two slot motherboard (Slots 3 and 4 of the Master Controller Bay) and provides one Style 4 or Style 7, RUI communications channel, available at Slot 4
- RUI communications controls up to 31 devices per master controller (on one or multiple RUI channels); devices include: MINIPLEX transponders, 4603-9101 LCD Annunciators, 4602-9101 Status Command Units (SCU), 4602-9102 Remote Command Units (RCU), 4602 Series LED Annunciator Panels, 4100 Series 24 I/O and LED/Switch modules
- Up to four RUI channels are supported; use up to three 4100-1291 RUI expansion modules as required
- A Network Interface Module is mounted in Slot 3
- Optional Service Modem 4100-6030 mounts onto the master controller board with its own on-board connections

System Power Supply:

- Rating is 9 A total, including module currents; NACs are disabled for NDU
- For NDU with VCC**, rated 9 A total with "Special Application" appliances; 4 A total for "Regulated 24 DC" appliance power; (see data sheet S4100-0031 for details)
- Outputs are power-limited, except for the battery charger

System Power Supply (Continued):

- Provides system power, battery charging, auxiliary power, earth detection, and provisions for either an optional City Connect Module or an optional Alarm Relay Module
- Battery Charger** is dual rate, temperature compensated, and charges up to 50 Ah sealed lead-acid batteries mounted in the battery compartment; also is UL listed for charging up to 115 Ah batteries mounted in an external cabinet (see data sheet S2081-0012 for details)
- Battery and Charger Monitoring** includes battery charger status and low or depleted battery conditions; status information provided to the master controller includes analog values for: battery voltage, charger voltage and current, actual system voltage and current, and individual NAC currents (where applicable)
- NDU, 2 A Auxiliary Power Output** is for local power requirements (SPS Aux relays are not used)
- NDU w/VCC, 2 A Auxiliary Power Output** is selectable for detector reset, door holder, or coded output operation
- Optional City Connect Module** (4100-6031, with disc. switches, or 4100-6032, without disc. switches) can be selected for conventional dual circuit city connections
- Optional Alarm Relay Module** (4100-6033) provides three Form C relays that are used for Alarm, Trouble, and Supervisory, rated 2 A resistive @ 32 VDC

NDU Equipment Selection

Network Display Unit, Non-Voice*

Model	Model Type/Listing		Description	Supv.	Alarm
4100-9141	120 VAC Input	UL	4100ES NDU with Master Controller , LCD and operator interface, Network Interface Module (select media card separately), 9 A system power supply/battery charger, and external RUI communications interface (power supply/battery charger is an SPS with its IDNet channel and NACs disabled)	419 mA	476 mA
4100-9143	Canadian, English	ULC		see below for selected Network Media Card current	
4100-9144	Canadian, French	ULC			
4100-9241	220-240 VAC Input	UL			

Network Display Unit with Voice Command Center (VCC)*

Model	Model Type/Listing		Description	Supv.	Alarm
4100-9142	120 VAC Input	UL	4100ES NDU with VCC includes the first bay equipment described for the NDU (above) and a second bay assembly with separate: Master Controller for voice functions, Network Interface (select media card separately), and a standard SPS with 250 point IDNet channel; and 3, 3 A Class A/B NACs capable of SmartSync two-wire operation	828 mA	907 mA
4100-9145	Canadian, English	ULC		see below for selected Network Media Card current	
4100-9146	Canadian, French	ULC			
4100-9242	220-240 VAC Input	UL			

* For InfoAlarm Command Center expanded content display products, refer to data sheet S4100-0045.

NDU, or NDU with VCC Communication Modules (with exceptions as noted)

Model	Description		Size	Supv.	Alarm	
4100-6056	Wired Network Media Card	Select per Network connection requirements, two media cards are required per network interface; mounts on the supplied Network Interface Module(s)	N.A.	55 mA	55 mA	
4100-6057	Fiber Optic Media Card		N.A.	25 mA	25 mA	
4100-6055	Network Access Dial-in Service Modem, mounts to supplied Network Interface Module, requires telephone line connection		N.A.	60 mA	60 mA	
4100-1291	Remote Unit Interface Module (RUI); up to three maximum per control panel		1 Slot	85 mA	85 mA	
4100-6030	Service Port Modem for local panel access only, mounts to Master Controller Module, requires telephone line connection, accesses same information as front panel port		N.A.	70 mA	70 mA	
4100-6031	City Circuit, with disconnect switches	For use with SPS only, not RPS	Select one per SPS (mounts on SPS/RPS)	N.A.	36 mA	
4100-6032	City Circuit, without disconnect switches			N.A.	20 mA	36 mA
4100-6033	Alarm Relay, 3 Form C relays, 2 A @ 32 VDC (one per RPS)			N.A.	15 mA	37 mA
4100-6038	Dual RS-232 Interface; 3 maximum; can mount in Slot 3 or Slot 2 of Master Controller		1 Slot	132 mA	132 mA	
4100-6046	Dual Port RS-232 standard interface (4 x 5 module)		1 Block	60 mA	60 mA	
4100-6052	DACT, Point or Event Reporting; includes 2, 14 ft (4.3 m) DACT cables		1 Slot	30 mA	40 mA	
4100-6101	Physical Bridge, Class B, includes 1 modem module and 2 wired modules		1 Slot	210 mA	210 mA	
4100-6102	Physical Bridge, Class A, includes 2 modem and 2 wired modules		2 Slots	300 mA	300 mA	
4100-0156	8 VDC Converter, required for multiple Physical Bridge Modules; 3 A @ 8 VDC maximum		1 Block	included with loads		
4100-9816	Master Clock Interface Module with one standard RS-232 port (see S4100-0033)		1 Slot	132 mA	132 mA	
4100-6079	SafeLINC internet interface module		2 Slots	145 mA	145 mA	

NDU with VCC, Emergency Voice/Alarm Communications Selection*

Model	Description	Details and Mounting Reference	
4100-1243	Master Microphone Module; one maximum per audio system; mounts on front panel	Requires 2 Slots (4" [102 mm]), locate on expansion bay only; space behind for 4100ES flat modules only <i>Supv. current = 2.4 mA; Active current = 6 mA</i>	
4100-1252	1 Channel (audio or mike)	Operator Interface Modules	Single slot modules requiring connection to an LED/switch controller (see page 9); space behind controller accepts 4100ES flat modules only Additional adjacent LED/switch module(s) are required for specific speaker circuit selection
4100-1253	1.5 Channel (audio + mike)		
4100-1254	2 Channel (full audio)		
4100-1255	3-8 Channel		

Firefighter Telephone System Products (refer to S4100-0034 for additional detail)

Model	Description	Details and Mounting Reference
4100-1270	Master Telephone with Telephone Control Module and 3 Class B telephone NACs; for Fire Alarm Control Panels	One max. per audio system; front panel module; space behind for 4100ES flat modules only; telephone control module mounts on bay module mounting plate; use LED/switch modules for circuit control
4100-1272	Telephone Module with 3 phone NACs	Class B NACs, single Block module, mounts to bay mounting plate
4100-1273	Telephone Class A Adapter Module	Mounts to 4100-1272, no additional space required

Analog Emergency Voice/Alarm Communications Equipment, Constant Supervision Compatible*

Model	Description	Details		
4100-9620	Basic Analog Audio Operation with microphone, requires dedicated expansion bay	Includes: Expansion Bay, 4100-1210 Analog Controller Board, Microphone Module, and Audio Expansion Bay Kit		
4100-1210	Analog Controller Board only; order expansion bay and audio expansion bay kit separately	Controller board mounts in Blocks A and B		
4100-1361	25 VRMS output	Flex-35, 35 W Amplifier, constant supervision compatible	NAC rating = 1.4 A	35 W, or 100 speakers
4100-1362	70.07 VRMS output		NAC rating = 0.5 A	
4100-1312	25 VRMS output	Flex-50, 50 W Amplifier, constant supervision compatible	NAC rating = 2 A	50 W, or 100 speakers
4100-1313	70.7 VRMS output		NAC rating = 0.707 A	

100 W Analog Amplifiers with Power Supply, Constant Supervision Compatible*

Model/Output Voltage		Power Supply Input/Listing		Description	Details	
25 VRMS	70.7 VRMS					
4100-1314	4100-1315	120 VAC, 60 Hz	UL	Primary 100 W Amplifier	Includes six, Class B audio NACs; NAC rating = 50 W or 100 speakers maximum; 2 A @ 25 VRMS; 1.4 A @ 70.7 VRMS	ULC models have low battery dropout circuit
4100-1316	4100-1317	120 VAC, 60 Hz	ULC			
4100-1318	4100-1319	220/230/240 VAC, 50/60 Hz	UL			
4100-1320	4100-1321	120 VAC, 60 Hz	UL	Backup 100 W Amplifier	Uses the six Class B NACs of primary amplifier	
4100-1322	4100-1323	120 VAC, 60 Hz	ULC			
4100-1324	4100-1325	220/230/240 VAC, 50/60 Hz	UL			

Digital Emergency Voice/Alarm Communications Equipment*

Model	Description	Details		
4100-9621	Basic Digital Audio Operation with microphone, requires dedicated expansion bay	Includes: Expansion Bay, 4100-1311 Digital Controller Board, Microphone Module, and Audio Expansion Bay Kit		
4100-1311	Eight Channel Digital Controller Board only; order expansion bay and audio expansion bay kit separately	Controller board mounts in Blocks A and B		
4100-1363	25 VRMS output	Flex-35, 35 W Amplifier, constant supervision compatible	NAC rating = 1.4 A	35 W, or 100 speakers
4100-1364	70.07 VRMS output		NAC rating = 0.5 A	
4100-1326	25 VRMS output	Flex-50, 50 W Amplifier, constant supervision compatible	NAC rating = 2 A	50 W, or 100 speakers
4100-1327	70.7 VRMS output		NAC rating = 0.707 A	

100 W Digital Amplifiers with Power Supply, Constant Supervision Compatible*

Model/Output Voltage		Power Supply Input/Listing		Description	Details	
25 VRMS	70.7 VRMS					
4100-1328	4100-1329	120 VAC, 60 Hz	UL	Primary 100 W Amplifier	Includes six, Class B audio NACs; NAC rating = 50 W or 100 speakers maximum; 2 A @ 25 VRMS; 1.4 A @ 70.7 VRMS	ULC models have low battery dropout circuit
4100-1330	4100-1331	120 VAC, 60 Hz	ULC			
4100-1332	4100-1333	220/230/240 VAC, 50/60 Hz	UL			
4100-1334	4100-1335	120 VAC, 60 Hz	UL	Backup 100 W Amplifier	Uses the six Class B NACs of primary amplifier	
4100-1336	4100-1337	120 VAC, 60 Hz	ULC			
4100-1338	4100-1339	220/230/240 VAC, 50/60 Hz	UL			

Options for use with either Analog or Digital Amplifiers*

Model	Description	Model	Description
4100-1245	Flex-35/50 NAC Expansion Module; (Adds 3 Class B, 1.5 A NACs)	4100-1248	100 W Amplifier NAC Expansion Module; (Adds six Class B, 2 A NACs)
4100-1246	Flex-35/50 Class A Adapter for 3 NACs	4100-1249	100 W Amplifier Class A Adapter Module for 6 NACs

* Refer to document S4100-0034 for additional audio module information.

NDU with VCC, Emergency Voice/Alarm Communications Selection (Continued)

Options for either Analog or Digital Systems (refer to data sheet S4100-0034 for additional module details)

Model	Description	Model	Description
4100-1259	Constant Supervision Adapter for 25 VRMS Amplifiers	4100-5116	Expansion Signal Module; three, 1.5 A NACs
4100-1260	Constant Supervision Adapter for 70.7 VRMS Amplifiers	4100-1266	NAC Extender
4100-1240	Auxiliary Audio Input Module; four additional inputs	4100-1267	Class A Adapter
4100-1241	8 Minute Message Expansion Module	4100-1268	Constant Supervision Adapter
4100-1242	32 Minute Message Expansion Module	4081-9018	End-of-line resistor for 70.7 VRMS NACs; 10 kΩ, 1 W
4100-0623	Network Audio Riser Controller Module for control of analog (-0621) or digital (-0622) riser module, see S4100-0034 for details		

NDU with VCC, LED/Switch Modules (refer to S4100-0032 for additional detail)

LED/Switch Modules, General Purpose (LED/switch controller and label kit is ordered separately)

Model	LEDs per Switch	LED Color(s)	LED Quantity	Switch Quantity
4100-1276	LEDs only	Red; pluggable	8	LEDs only
4100-1277		Red on top, Yellow on bottom, pluggable	16	
4100-1280	One	Red	8	8
4100-1281	One	Yellow		
4100-1282	Two	Red on top, Yellow on bottom	16	
4100-1283	Two	Yellow, top and bottom		
4100-1284	Two	Red on top, Green on bottom		
4100-1296	Two	Green on top, Yellow on bottom		
4100-1285	One	Red	16	16
4100-1278	One	8 Red on left, 8 Yellow on right		
4100-1287	One	Red	24	24

LED/Switch Modules, Special Purpose (LED/switch controller and label kit is ordered separately)

Model	Operation
4100-1286	Eight function HOA (On, Off, Auto) Control Module with labeled switches; ON/OFF/Auto; Green/Red/Green LEDs
4100-1295	Eight function HOA (On, Off, Auto) Control Module, same as 4100-1286 except switches are unlabeled

LED/Switch Controller Modules and Accessories

Model	Description
4100-1288	64 LED/64 Switch Controller Module with mounting plate; controls up to 64 LEDs and interfaces to up to 64 switches; mounts behind the LED/switch modules and has provisions for one 4100-1289 Controller Module
4100-1289	64 LED/64 Switch Controller Module without mounting plate; mounts on extra space of 4100-1288; controls an additional 64 LEDs and 64 switches
4100-1294	LED/Switch Module Slide-in Labels, required when LED/switch modules are present ; order one per cabinet

NOTE: LED/switch controllers and their connected LED/switch modules must be in the same bay; refer to data sheet S4100-0032 for additional LED/Switch module details when Flex-35/50 amplifiers are in the same bay

Model	Color	Model	Color	Model	Color	Description
4100-9843	Yellow	4100-9844	Green	4100-9845	Red	Kits of 8 LEDs; order as required for 4100-1276/1277 modules

NDU with VCC, Expansion and Remote Power Supplies and Accessories

Model	Voltage/Listing		Description	Size	Supv.	Alarm
4100-5101	120 VAC	UL	Expansion Power Supply (XPS); 9 A output rated same as SPS, 3 built-in 3 A Class A/B NACs that can provide synchronized strobe or SmartSync, two-wire operation	2 Blocks	50 mA	50 mA
4100-5103	120 VAC, Canadian	ULC				
4100-5102	220-240 VAC	UL				
4100-5115	NAC Expansion Module, 3 NACs, Class A/B, mounts on XPS only			N.A.	25 mA	25 mA
4100-5111	120 VAC	UL	Additional System Power Supply (SPS); 9 A power supply/charger with 250 point IDNet channel; 3, 3A Class A/B NACs, expansion slot for City Circuit or Alarm Relay option; Canadian model has low battery cutout	4 Blocks	175 mA	185 mA
4100-5112	120 VAC, Canadian	ULC				
4100-5113	220-240 VAC	UL				
4100-5125	120 VAC	UL	Remote Power Supply (RPS); 9 A power supply/charger similar to SPS except no IDNet channel or City Circuits; will accept one 4100-6033	4 Blocks	150 mA	185 mA
4100-5126	120 VAC, Canadian	ULC				
4100-5127	220/230/240 VAC	UL				
4100-5152	12 VDC Power Option, 2 A @ 12 VDC maximum			1 Block	1.5 A maximum	
4100-0634	120 VAC	Power Distribution Module (PDM); select per system voltage; one required per box or cabinet rack				
4100-0635	220/230/240 VAC					

NDU with VCC – Additional Options

Model	Description				
4100-6034	Door Tamper Switch with built-in addressable IDNet IAM, one per cabinet assembly if required				
4100-2320	Audio Bay-to-Bay Interconnection Harness Kit; order one for each audio bay addition				
4100-0637	Audio Box Interconnection Harness Kit; order one for each close-nipped audio cabinet				
4100-9835	Termination and Address Label Kit (for module marking); provides additional labels for field installed modules				
4100-1290	24 Point I/O Module; I Slot (see data sheet S4100-0032 for details)				
4100-1293	Panel Mount Thermal Printhead Printer, supplied with one roll of paper; requires 3 Slots; see S4100-0032 for details				
4190-9803	Replacement Paper for 4100-1293 Printer, one roll				
4100-6045	Coded Manual Station Decoder Module; 3 Slot module; 85 mA supervisory, 163 mA alarm; see S4100-0018 for details				
4100-6048	VESDA Air Aspiration Interface; 1 Slot module; 132 mA supervisory or alarm, see S4100-0026 for details				
Model*	Description	Model*	Description	Model*	Description
4100-5005	8 Zone IDC, Class B	4100-3101	250 Point IDNet Module	4100-3202	4 DPDT Relays w/feedback, 10 A
4100-5015	8 Zone IDC, Class A	4100-3102	127 Point MAPNET II Module	4100-3204	4 DPDT Relays w/feedback, 2 A
* See S4100-0031 for details		4100-3103	IDNet/MAPNET II Quad Isolator	4100-3206	8 SPDT Relays, 3 A

NDU or NDU with VCC Additional Options

Model	Description
4100-1279	Single blank 2" display cover; order as required (8 fill a bay front); two max. in a row between LED/switch modules
4100-2210	Appiqué, Canadian French, 4100ES Fire Control
4100-2300	Expansion Bay Hardware, order for each expansion bay (unless included with selected option)
4100-0636	Box Interconnection Harness Kit; order one for each close-nipped cabinet
4100-0632	Terminal Block Module; 2, 16 position terminal blocks mounted on 4" x 5" single block size, for up to 12 AWG wire (3.31 mm ²)
4100-5128	Battery Distribution Terminal Block; mounts to side of box; required for close-nipped cabinets that interconnect battery wiring

General Specifications

Input Power [System (SPS); Expansion (XPS); Remote (RPS); and 100 W amplifiers]	120 VAC Models	4 A maximum @ 102 to 132 VAC, 60 Hz	
	220-240 VAC Models	2 A maximum @ 204 to 264 VAC, 50/60 Hz; separate taps for 220/230/240 VAC	
Power Supply Output Ratings for SPS, XPS, and RPS (see data sheet S4100-0031 for more detail)	Total Power Supply Output Rating	Including module currents and auxiliary power outputs; 9 A total for "Special Application" appliances; 4 A total for "Regulated 24 DC" power	Output switches to battery during AC failure or brownout
	Auxiliary Power Tap		
	NACs Programmed for Auxiliary Power	2 A maximum per NAC; 5 A maximum total	
Battery Charger Ratings for SPS and RPS (sealed lead-acid batteries)	Battery capacity range	UL listed for battery charging of 6.2 Ah up to 115 Ah (batteries larger than 50 Ah require a remote battery cabinet); ULC listed for charging up to 50 Ah batteries	
	Charger characteristics and performance	Temperature compensated, dual rate, recharges depleted batteries within 48 hours per UL Standard 864, to 70% capacity in 12 hours per ULC Standard S527	
Environmental	Operating Temp. Range	32° to 120°F (0° to 49° C)	
	Operating Humidity Range	Up to 93% RH, non-condensing @ 90° F (32° C) maximum	

Expansion Bay Module Loading Reference (exact locations are provided with shipped product)

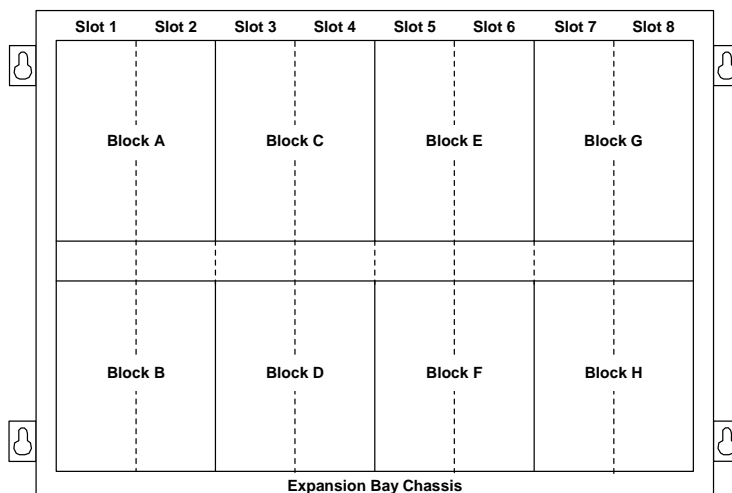

Size Definitions: Block = 4" W x 5" H (102 mm x 127 mm) card area
Slot = 2" W x 8" H (51 mm x 203 mm) motherboard with daughter card

Description	Mounting
Terminal Block Module	4" x 5", 1 block
Class B Physical Bridge	2", 1 slot
Class X Physical Bridge	4", 2 slots
System or Remote Power Supply	Blocks E, F, G & H ONLY
Expansion Power Supply	Blocks G & H ONLY
Audio Controller Modules	Blocks A & B
Flex-35 Amplifiers, 2 max/bay*	Blocks E & F; C & D; or A & B
Flex-50 Amplifiers, 2 max/bay*	Blocks E & F or C & D
100 W Amplifiers, 1 max/bay	Blocks E, F, G & H
100 W Backup Amplifiers, 1 max. per bay with primary amplifier	Blocks A, B, C & D
Master Telephone Module	Blocks A & B
Master Microphone Module (do not mount next to telephone)	Two vertical Blocks, any location
Telephone Module	1 Block
Operator LED/Switch Modules	1 Slot

* **NOTE:** When mounting dual Flex amplifiers on an expansion bay, special mounting rules apply.

Wall Mounted Enclosure Installation Reference

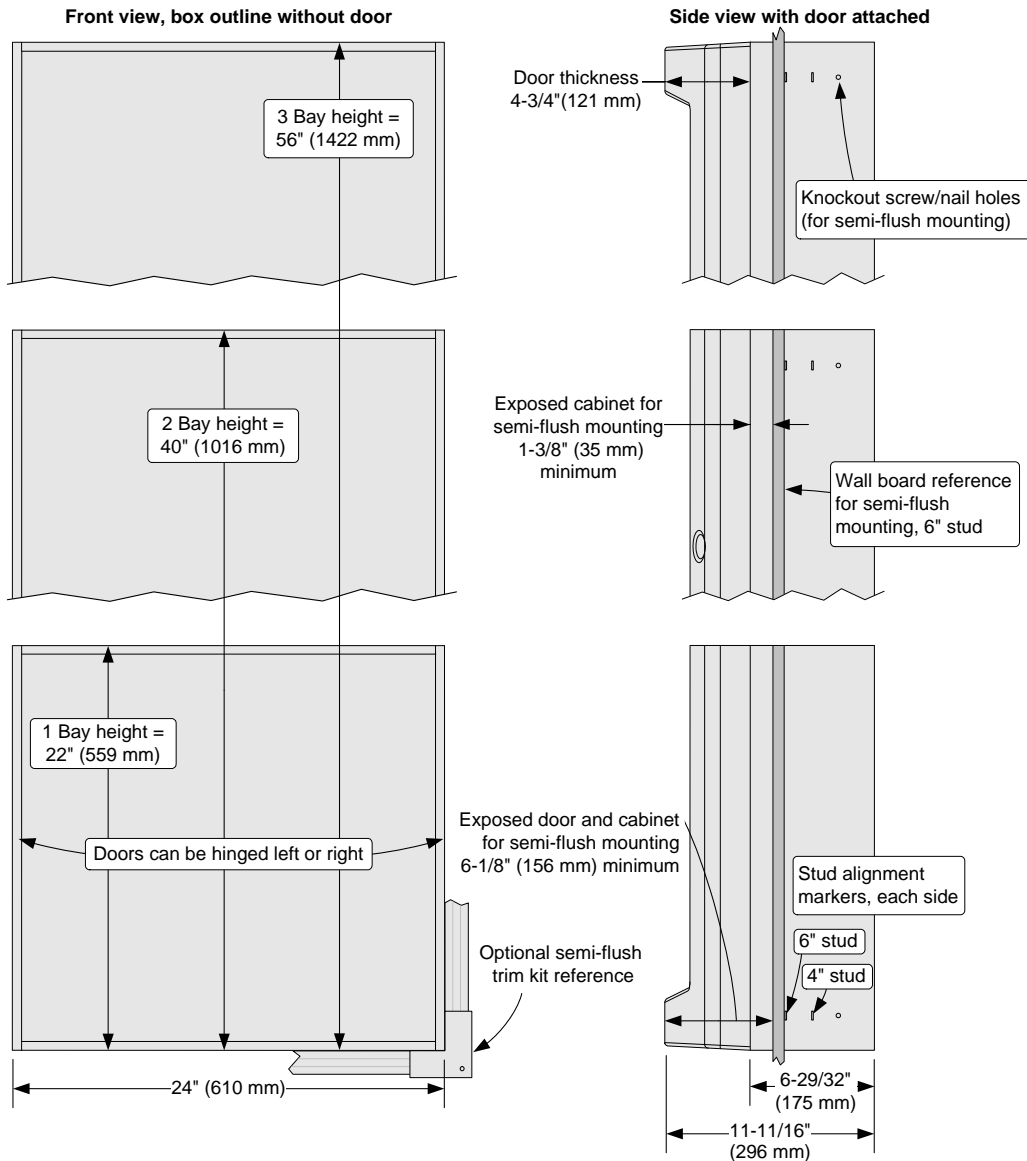

NOTE: A system ground must be provided for Earth Detection and transient protection devices. This connection shall be made to an approved, dedicated Earth connection per NFPA 70, Article 250, and NFPA 780.

Additional 4100ES Technical Reference

Installation Instructions	574-848
Operating Instructions	579-197

Additional 4100ES Data Sheet Reference

Subject	Data Sheet	Subject	Data Sheet
NDU with EPS Power Supplies	S4100-0102	MINIPLX Transponders	S4100-0035
4100ES Basic Panels with EPS Power Supplies	S4100-0100	4100ES Enclosures	S4100-0037
4100ES Basic Panels	S4100-0031	Remote Annunciators	S4100-0038
LED/Switch Modules	S4100-0032	Remote Battery Charger	S4081-0002
4100ES Audio/Phone Modules	S4100-0034	Fiber Optic Modems	S4100-0043
SafeLINC Fire Panel Internet Interface	S4100-0062	TrueSite Workstation	S4190-0016
InfoAlarm Command Center	S4100-0045	Master Clock Interface Module	S4100-0033

TYCO, SIMPLEX, and the product names listed in this material are marks and/or registered marks. Unauthorized use is strictly prohibited. Microsoft and Windows are registered trademarks of Microsoft Corporation. VESDA is a trademark of Vision Products Pty Ltd.



Tyco Fire Protection Products • Westminister, MA • 01441-0001 • USA

S4100-0036-13 5/2013

www.simplexgrinnell.com

© 2013 Tyco Fire Protection Products. All rights reserved. All specifications and other information shown were current as of document revision date and are subject to change without notice.