



3825 Ohio Avenue, St. Charles, Illinois 60174  
1-800-SENSOR2, FAX: 630-377-6495

## 2400 and 2400TH Direct Wire Photoelectronic Smoke Detectors

### Specifications

Diameter:	5.5 inches (140 mm)
Height:	3.14 inches (80 mm) Add 0.5 inches (13 mm) for 2400TH
Weight:	0.7 lb. (310 gm)
Operating Temperature Range:	Model 2400 — 0° to +49°C (32° to 120°F) Model 2400TH — 0° to 38°C (32° to 100°F)
Operating Humidity Range:	10% to 93% Relative Humidity Non-condensing
Maximum Air Velocity:	3000 ft/min (15m/s)
Locking Alarm:	Reset by momentary power interruption

### Electrical Ratings

System Voltage:	12/24 VDC
Maximum Ripple Voltage:	4 Volts peak-to-peak
Start-up Capacitance:	0.02 $\mu$ F Maximum
Standby Ratings:	8.5 VDC Minimum; 35 VDC Maximum 120 $\mu$ A Maximum
Alarm Ratings:	4.2 VDC Minimum at 10 mA 6.6 VDC Maximum at 100 mA Alarm current must be limited to 100mA maximum by the control panel. If used, the RA400Z Remote Annunciator operates within the specified detector alarm currents.
Reset Voltage:	2.5 VDC Minimum
Reset Time:	0.3 S Maximum
Start-up Time:	34 S Maximum

### Before Installing

Please thoroughly read the System Sensor manual A05-1003, *Applications Guide for System Smoke Detectors*. This manual provides detailed information on detector spacing, placement, zoning, wiring, and special applications. Copies of this manual are available at no charge from System Sensor (For installations in Canada refer to CAN4-S524, *Standard for the Installation of Fire Alarm Systems* and CEC Part 1, Sec. 32).

**NOTICE:** This manual should be left with the owner/user of this equipment.

**IMPORTANT:** This sensor must be tested and maintained regularly following NFPA 72 requirements. This sensor should be cleaned at least once a year.

### General Description

System Sensor 2400 photoelectronic detectors use state-of-the-art, optical sensing chambers. These detectors are designed to provide open area protection, and are intended for use with compatible UL-listed 2-wire control panels only. The detector's operation and sensitivity can be tested in place. Model 2400TH has the same specifications as

model 2400, but also features a restorable, built-in, fixed temperature (135°F) thermal detection unit.

These detectors are listed to UL 268 and are latching type system detectors. When latched in alarm, the detectors must be reset by a momentary power interruption.

An LED on the detector provides a local indication of the detector's status. This LED blinks every 10 seconds when the detector is receiving power and ready in standby and is latched on continuously in alarm until the detector is reset. The detector provides an output for connection to an optional Remote Annunciator (Model RA400Z). The Remote Annunciator mounts to a single gang box and provides a supplementary alarm indication.

### Spacing

NFPA 72E defines the spacing requirements for smoke detectors, typically 30 feet when detectors are installed on a smooth ceiling. However, ALL installations must comply with NFPA 72 and/or special requirements of the authority having jurisdiction.

**Figure 1. Flush mounting of 2400TH smoke detector on 3½-inch and 4-inch octagonal box:**

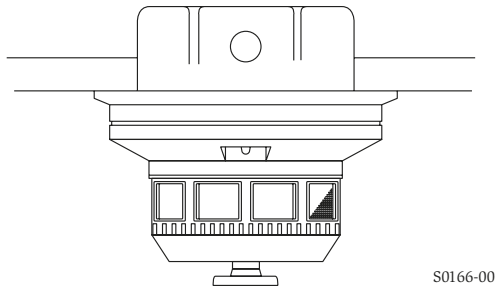

S0166-00

**Mounting**

Each 2400 detector is supplied with a mounting bracket kit that permits the detector to be mounted:

1. Directly to a 3½-inch or 4-inch octagonal, 1½-inch deep electrical box, (See Figure 1) or:
2. To a 4-inch square electrical box by using the plaster ring with the supplied mounting bracket kit.

**Installation Wiring Guidelines**

All wiring must be installed in compliance with the National Electrical Code and all applicable local codes, and any special requirements of the local authority having jurisdiction. Proper wire gauges should be used. The conductors used to connect smoke detectors to control panels and accessory devices should be color-coded to reduce the likelihood of wiring errors. Improper connections can prevent a system from responding properly in the event of a fire.

For signal wiring (wiring between interconnected detectors), wire no smaller than AWG 18 is recommended. However, the screws and clamping plate in the base can accommodate wire sizes up to AWG 12. The use of twisted pair wiring for the power (+ and -) loop is recommended to minimize the effects of electrical interference.

Smoke detectors and alarm system control panels have specifications for allowable loop resistance. Consult the control panel manufacturer’s specifications for the total loop resistance allowed for the control panel being used before wiring the detector loops.

**Figure 2. 2400 Smoke detector mounting bracket:**

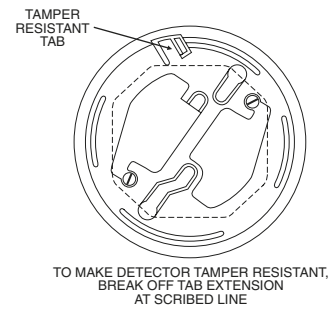

S0140-00

Make wire connections by stripping about 3/8 inch of insulation from the end of the wire and sliding the bare end of the wire under the clamping plate, and tightening the clamping plate screw. A wiring diagram for a typical 2-wire detector system is shown in Figure 3.

System Sensor’s smoke detectors are marked with a compatibility identifier located as the last digit of a five-digit code stamped on the back of the product. Connect detectors only to compatible control units as indicated in System Sensor’s compatibility chart which contains a current list of UL-listed control units and detectors. A copy of this list is available from System Sensor upon request.

**NOTE:** For system supervision — do not loop wire under terminals 1 and 2.

**NOTE:** If remote annunciator is not used, polarity to detector may be reversed.

**Tamper-resistant Feature**

This detector includes a tamper-resistant feature that prevents removal of the detector without the use of a tool. To make the detector tamper-resistant, break off the smaller tab at the scribed line on the tamper resistant tab, on the detector mounting bracket (see Figure 2), then install the detector. To remove the detector from the bracket once it has been made tamper resistant, use a small screwdriver to depress the tamper-resistant tab located in the slot on the mounting bracket and turn the detector counterclockwise for removal.

**Figure 3. Wiring diagram for 2400 smoke detector used with two-wire control panel:**

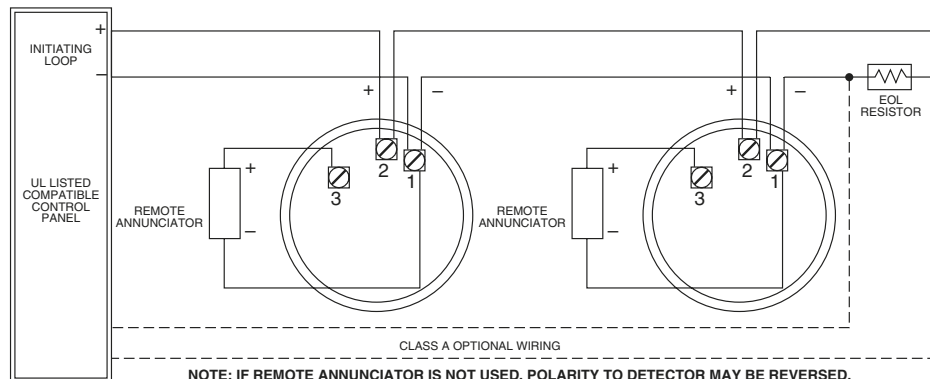

S0141-00

## Installation

### ⚠WARNING

Disable the power from initiating device circuits before installing detectors.

1. Wire each detector following installation guidelines.
2. Line up arrows on the detector with arrows on the mounting bracket.
3. Turn the detector clockwise until it clicks into place.
4. After all detectors have been installed, apply power to the control unit.
5. Test the detector as described under TESTING.
6. Reset the detector at the system control panel.
7. Notify the proper authorities the system is in operation.

### ⚠CAUTION

Dust covers can be used to help limit dust entry to the detector. However, these covers are not a substitute for removing the detector during building construction. Remove any dust covers before placing the system in service.

### ⚠CAUTION

Smoke detectors are not to be used with detector guards unless the combination has been evaluated and found suitable for that purpose.

## Testing

Before testing, notify the proper authorities that the smoke detector system is undergoing maintenance, and the system will be temporarily out of service. Disable the zone or system undergoing maintenance to prevent unwanted alarms.

Before testing the detector, look for the presence of the flashing LED. If it does not flash, power has been lost to the detector (check the wiring), or it is defective (return for repair – refer to Warranty information).

Detectors must be tested after installation and following periodic maintenance. The 2400/2400TH may be tested as follows:

**Figure 4. Top and side views showing position of test switch:**

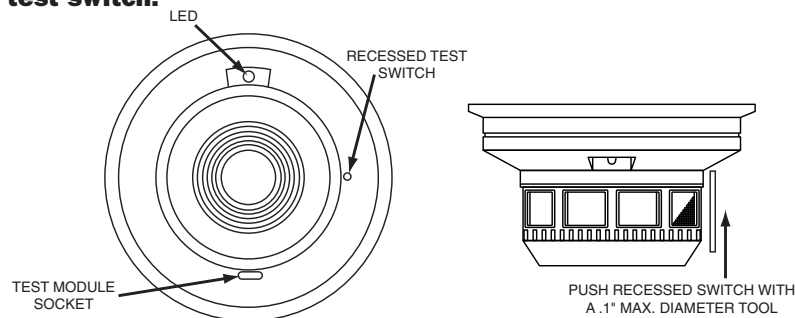

S0167-00

D400-05-00

## A. Functional Tests

### Recessed Test Switch

1. A test switch is located on the detector housing (See Figure 4).
2. Press and hold the recessed test switch with a 0.1 inch maximum diameter tool.
3. The detector's LED should light within 5 seconds.

## B. Calibrated Test Card (R59-18-00)

1. Remove the detector cover by placing a small bladed screwdriver in the side slot of the detector cover, twisting it slightly until the cover can be turned counterclockwise for removal.
2. Insert the NO ALARM end of the test card fully into the test slot (See Figure 5) then slide it counterclockwise until it stops.
3. The detector should not alarm after 20 seconds.
4. Remove the test card by sliding it clockwise before removing, then insert the ALARM end.
5. The LED should latch on within 20 seconds. An alarm should also be initiated at the panel.

6. Put the cover back by gently rotating it clockwise until it locks in place.

## C. Test Module (System Sensor No. MOD400R/MOD400). The MOD400R or MOD400 Test Module is used with an analog or digital voltmeter to check the detector sensitivity as described in the test module's manual.

## D. Aerosol Generator (Gemini 501).

Set the aerosol generator to represent 4%/ft. to 5%/ft. obscuration as described in the Gemini 501 manual. Using the bowl shaped applicator, apply aerosol until unit alarms.

## E. Direct Heat Test (2400TH only).

To test the bi-metallic thermal collector on the 2400TH, use a low powered heat gun or blow dryer, aiming the heat source across the detector. Hold the heat source about 12 inches (30 cm) from the detector to avoid damaging the plastic. When the heat rises to greater than 135°F, the detector will latch in alarm. After the test, the bi-metallic collector will self-restore.

Notify the proper authorities that the system is back on line.

Detectors that fail these tests should be cleaned as described under MAINTENANCE and retested. If the detectors still fail these tests, they should be returned for repair.

## Maintenance

**NOTE:** Before removing the detector, notify the proper authorities the smoke detector system is undergoing maintenance and, therefore, will be temporarily out of service. Disable the zone or system undergoing maintenance to prevent unwanted alarms.

1. Remove the detector cover by placing a small bladed screwdriver in the side slot of the detector cover, twisting it slightly until the cover can be turned counterclockwise for removal.
2. Vacuum the screen carefully without removing it. If further cleaning is required continue with step 3, otherwise skip to step 6.
3. See Figure 5. Remove the screen by pulling it straight out. Vacuum the inside.
4. Clean the vaned chamber piece by vacuuming or blowing out dust and particles.
5. To replace the screen, orient it so that the arrow on top aligns with the test module socket of the detector. Carefully push the screen onto the base, making sure it fits tightly to the chamber.
6. Replace the cover by gently rotating it clockwise until it locks in place.
7. Notify the proper authorities the system is back on line.

**Figure 5. Removal of cover and screen for cleaning:**

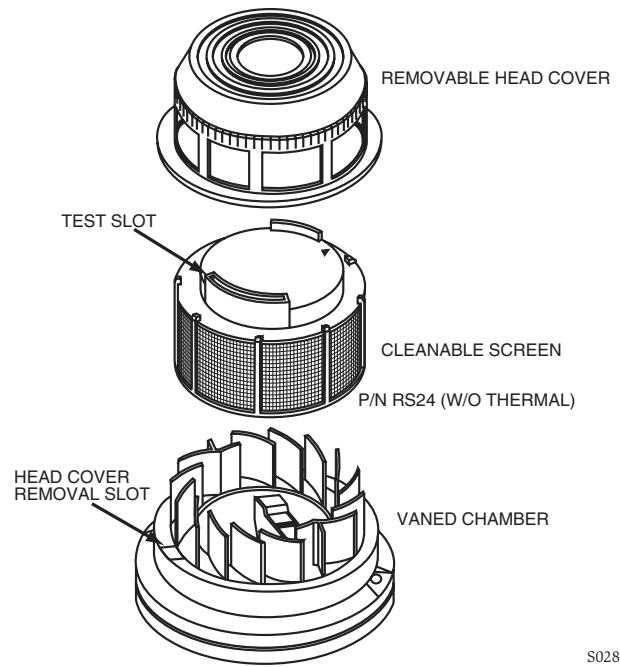

S0288-00

## Please refer to insert for the Limitations of Fire Alarm Systems

### Three-Year Limited Warranty

System Sensor warrants its enclosed smoke detector to be free from defects in materials and workmanship under normal use and service for a period of three years from date of manufacture. System Sensor makes no other express warranty for this smoke detector. No agent, representative, dealer, or employee of the Company has the authority to increase or alter the obligations or limitations of this Warranty. The Company's obligation of this Warranty shall be limited to the repair or replacement of any part of the smoke detector which is found to be defective in materials or workmanship under normal use and service during the three year period commencing with the date of manufacture. After phoning System Sensor's toll free number 800-SENSOR2 (736-7672) for a Return Authorization number, send defective units postage prepaid to: System Sensor, Repair

Department, RA # \_\_\_\_\_, 3825 Ohio Avenue, St. Charles, IL 60174. Please include a note describing the malfunction and suspected cause of failure. The Company shall not be obligated to repair or replace units which are found to be defective because of damage, unreasonable use, modifications, or alterations occurring after the date of manufacture. In no case shall the Company be liable for any consequential or incidental damages for breach of this or any other Warranty, expressed or implied whatsoever, even if the loss or damage is caused by the Company's negligence or fault. Some states do not allow the exclusion or limitation of incidental or consequential damages, so the above limitation or exclusion may not apply to you. This Warranty gives you specific legal rights, and you may also have other rights which vary from state to state.